

UC-NRLF



B 3 018 745

5 CENTS

TJ
7
M3
v.7

LATHE AND PLANER TOOLS

FOURTH REVISED AND ENLARGED EDITION

STANDARD SHOP TOOLS AND THEIR USE
CUTTING SPEEDS AND FEEDS

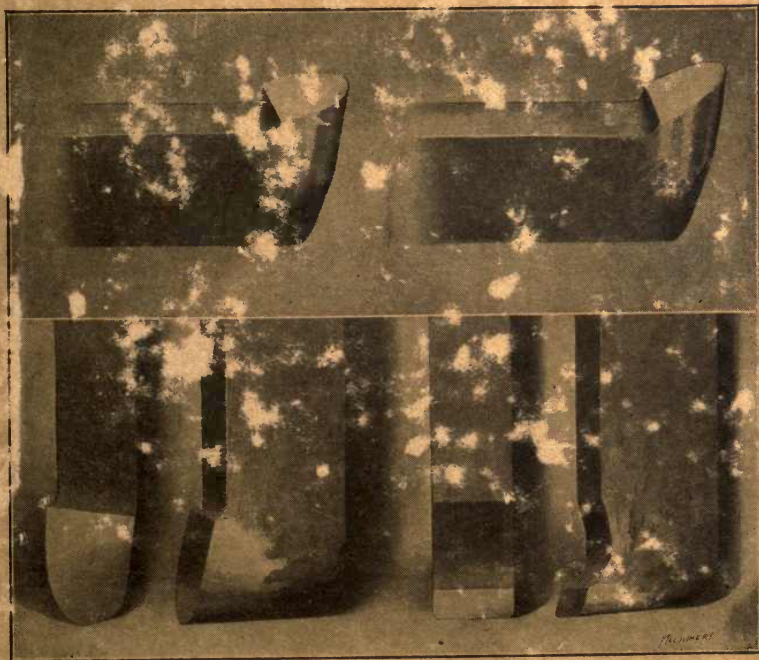

MACHINERY'S REFERENCE BOOK NO. 7
PUBLISHED BY MACHINERY, NEW YORK

JAN 5

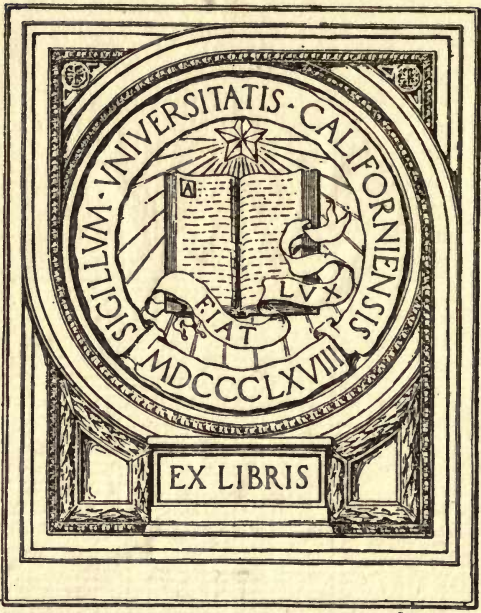

EX LIBRIS

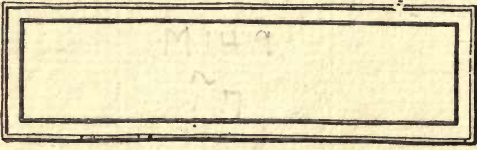

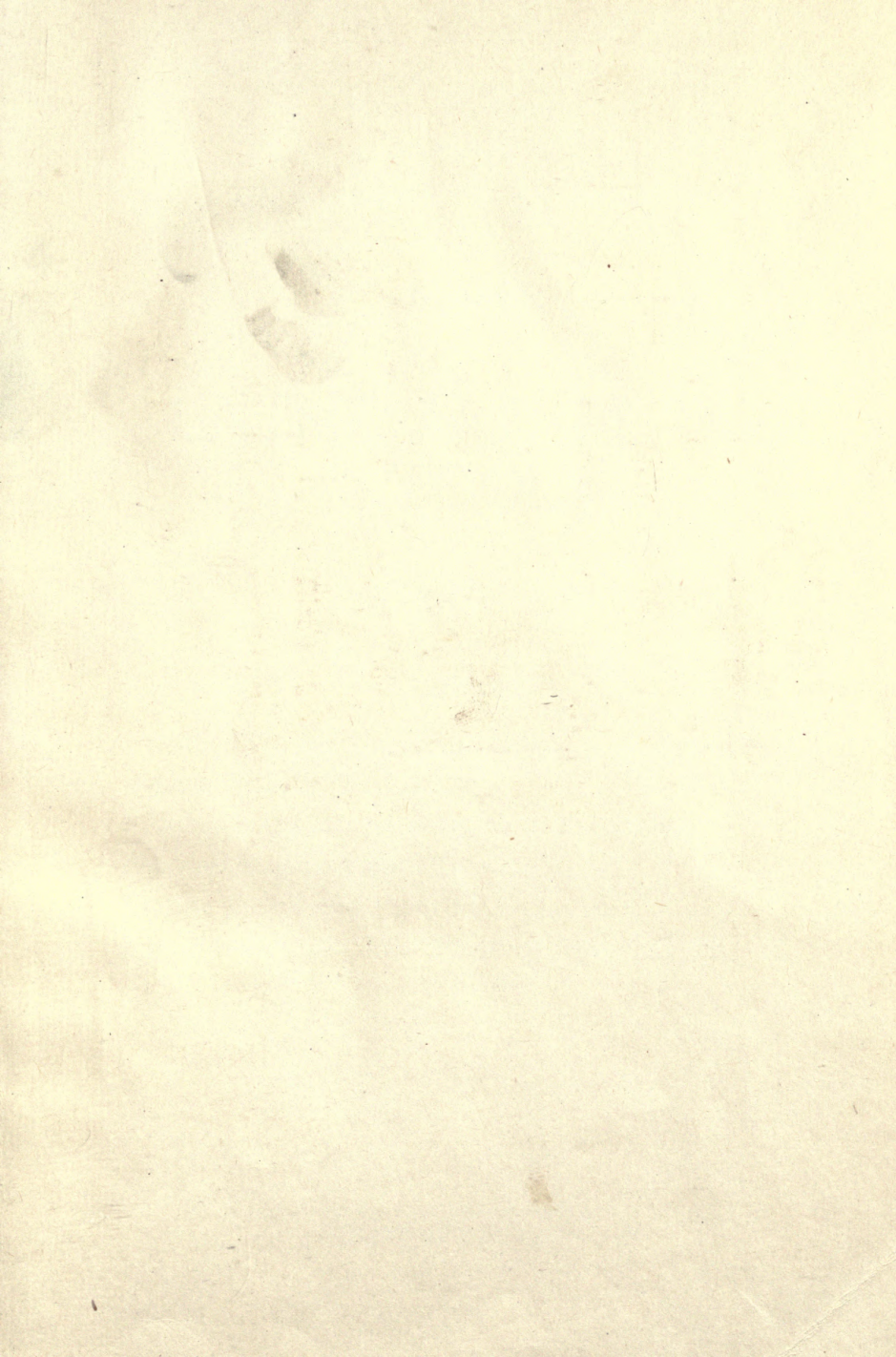

MACHINERY'S REFERENCE SERIES

EACH NUMBER IS A UNIT IN A SERIES ON ELECTRICAL AND
STEAM ENGINEERING DRAWING AND MACHINE
DESIGN AND SHOP PRACTICE

NUMBER 7

LATHE AND PLANER TOOLS

FOURTH REVISED EDITION

CONTENTS

Cutting Tools for Planer and Lathe, by W. J. KAUP	-	3
Boring Tools, by W. J. KAUP	- - - -	11
Forging Lathe Boring Tools, by J. F. SALLOWS	- -	17
Shape of Standard Shop Tools	- - - -	20
Cutting Speeds and Feeds for Lathe Tools	- - -	29
Straight and Circular Forming Tools, by JOS. M. STABEL and GEO. D. HAYDEN	- - - -	34

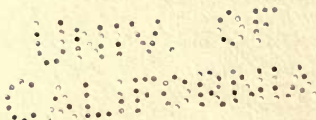

TJ7
M3
v.7

LEATHER AND TANNER
TOOLS

THE
UNIVERSITY OF
MICHIGAN

CHAPTER I

CUTTING TOOLS FOR PLANER AND LATHE*

In discussing cutting tools for the planer and lathe, planer tools will first come under our notice as being the simplest and requiring the least skill in setting. Every mechanic has doubtless observed that if the chip be unwound from the spiral shape it assumes in leaving the tool, and projected in a straight line, it is shorter than the surface from which it came. This is due mainly to the compression of the metal in the direction of the cut, and the possibilities of saving power and strain upon the machine by giving proper cutting angles to the tools and reducing this compression to a minimum is thus realized.

Rake of Planer Tools

In Fig. 1 the cutting tool is at right angles to the work and without rake. It exerts its force in a direction nearly parallel to the surface

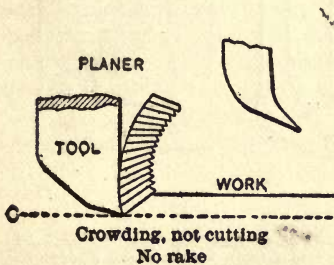

Fig. 1. Tool without Rake, and with Excessive Rake

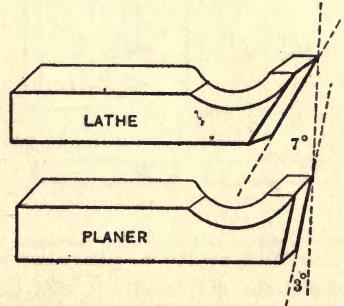

Fig. 2. Proper Rake on Lathe and Planer Tools

of the work, and having no side rake either, it simply does not cut, but shoves or crowds the metal forward, producing a chip made up of little splints. It cannot exert any force tending to lift or curl the chip. The tool is wholly wrong; nor would it materially improve it to grind it like the tool shown in the little sketch at the right, which goes to the other extreme, and would spring into the work. A tool must first of all be heavy enough at the back or heel to resist the horizontal cutting force, and consequently should have very little clearance. The 7 degrees clearance shown in the lathe tool in the upper view, Fig. 2, is too much for a planer tool, while the 3 degrees of the lower sketch is as small as can be used safely. Theoretically if the point leads by only a thousandth or two it will perform its function. There should be very little top rake on account of its tendency to make the tool dig into the cut; but this can be compensated for by giving considerable side rake.

* MACHINERY, August, 1903.

Another reason why a planer tool tends to dig into the work is illustrated in Fig. 3. Point *A* in the sketch is the fulcrum. In the first sketch the tendency is for the tool to dig into the work in the direction of the arrow. This is not so serious as appears on the face of it, as planer tools are usually so stiff that they will spring but little, and any error that might occur in the roughing cut would be eliminated in the finishing cut. What many mechanics take as an indication of the spring of the tool is really due to the chatter of the planer, since a rack and pinion planer will frequently chatter after it has become worn, while in a worm-driven planer the lost motion is all taken up at one end before beginning the cut, and the screw action does away with the chatter. To obviate any spring into the work, the tool may be designed as in the second sketch, Fig. 3, where the deflection due to the force of cut is away from the work.

The tool in Fig. 4 approaches the ideal for a finishing tool, and gives the best finished surface of any used on planer or shaper. It is made from a piece of ordinary tool steel and forged on the end to

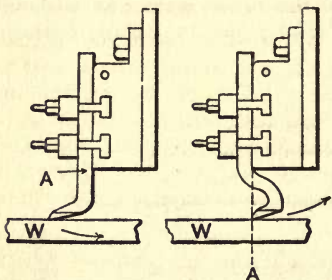

Fig. 3. Cause of Planer Tools Springing into the Work, and Means for Avoiding this

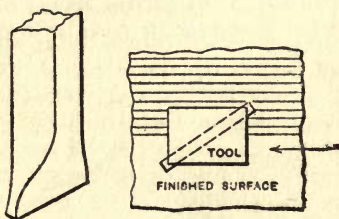

Fig. 4. Finishing Tool of Approved Design for Planer or Shaper

the shape indicated. It will be noticed that it has side rake, and instead of being straight on the bottom, the line that comes in contact with the work is a little rounding.

The Cutting Edges of Lathe Tools

We will now take up the subject of the cutting edges of some of the many varieties of lathe tools, Fig. 5. Here are shown diamond point, round-nose, side, centering, thread-cutting and cutting-off tools. We will first of all consider the diamond point tool, as it is by far more of a universal tool than any of the others. Before speaking of rake, clearance, or the setting of the tool, attention should be called to the general form of the cutting edges and the importance of maintaining the same throughout the life of the tool. Fig. 7 will best illustrate this. The tool as shown at the left, with depth of cut, is ground so that angle α shall not be less than 55 degrees. To the right is a tool in which the angle has been changed by grinding on both sides of the point, only because the machinist claims that he is in a hurry and must make time on his work. But it will be seen that the length of cut b is much greater than the line of resistance a , showing loss in efficiency in the tool, and requiring more power to drive it after it had

been ground. Nor is this the only reason why careless grinding will produce a loss. This is true with proper rake, angles and clearance, but when the mechanic ignores all principles and is careless, besides, how much more serious it becomes, because more finishing cuts will be required to make the piece straight. The nearer the cutting edge of the tool comes to being parallel with the axis of the work, the more power will be required to operate the tool.

It will be interesting to note what really takes place in turning, as shown in diagrammatic form in Fig. 8. Here is represented a piece

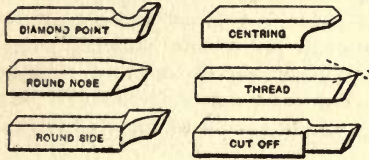

Fig. 5. Various Classes of Lathe Tools

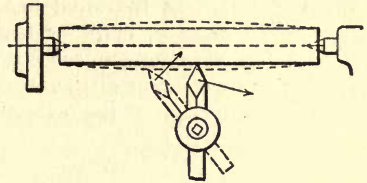

Fig. 6. Correct and Incorrect Setting of Tool

of rough stock that is to be turned as indicated at the right. First, starting at the center line *A*, and developing the line of circumference in a straight path, we will get a line like (1). After turning and repeating the process, the developed line will look like the line at (2). It will be noted that the second line is somewhat irregular, showing that even after roughing off, the surface of the piece has nearly all the irregularities of the rough stock, though on a smaller scale. This

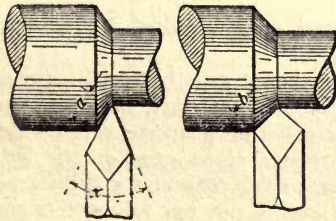

Fig. 7. Effect of Grinding Tool to Improper Angles

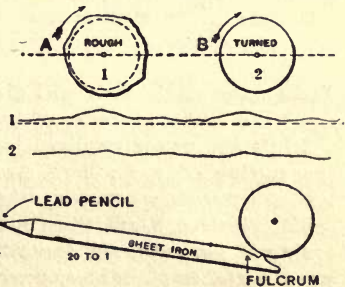

Fig. 8. Diagram Indicating Uneven Surfaces of Rough and Finished Work

brings us to another important point, and that is the necessity of centering work as accurately as possible, for no matter how even the work may be on its circumference, if centered out of true, it will not be round after turning, because the thickness of the chip or shaving is not uniform, hence does not offer uniform resistance to the cutting edge, and the work will bend more at one point than at another. If the cut were uniform and offered the same resistance, of course we could expect round work.

The bottom figure in Fig. 8 illustrates the tool for, and method of, obtaining the lines. A long light lever has a knife edge or point at one end, near the fulcrum, which bears against the periphery of the

work. On the other end is a lead pencil attachment, the point bearing against the piece of paper indicated, the paper traveling at the same rate of speed as the work, only in the direction of the axis of the work. Any unevenness in the surface of the work raises or lowers the point of the pencil, and as the ratio is great (20 to 1), the variation in the line is marked.

Rake and Clearance

Referring to Fig. 2, we will take up the rake and clearance of lathe diamond point tools. The angle of clearance, sometimes called the angle of relief, as indicated here, is about 7 degrees, and sometimes runs to 10 degrees, more or less—enough for a safe working angle. Really, the only reason for so much clearance is to avoid rubbing against the cut surface, thereby causing unnecessary frictional resistance to the motion of the lathe. Our efforts should be directed toward

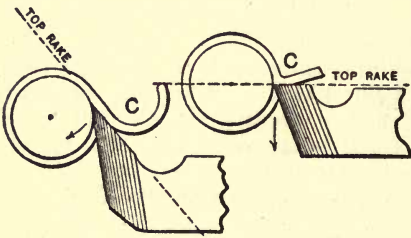

Fig. 9. Extreme Cases of Top Rake

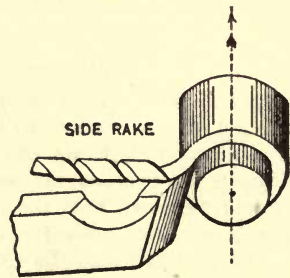

Fig. 10. Properly Ground Tool, having Side Rake

finding the angle that will give the least force required for cutting, combined with endurance of the tool edge.

While the power required to cut is increased greatly by dullness of the cutting edge, we must avoid the wood chisel edge, because time lost in constantly removing the tool for grinding purposes eats up the profit. In Fig. 9 are illustrated two extreme cases—that on the left, too great top rake, and the other, without any. The one will do good work for a few minutes, provided the cut is not too heavy, but the wear of the edge is so great that the angle will soon become blunt, and it would be very much better to have no top rake at all. On the other hand, the cutting wedge, as I will call the tool shown at the right, is too blunt to do good, clean work, and from the position in which it is set, the chip will come off nearly straight and in small pieces. The happy medium between the two is indicated in Fig. 10.

Side rake means the angle at which the top is ground either to the right or left side. A tool ground for a traversing motion toward the left-hand, cannot be used with a motion toward the right. Therefore side rake is designated right-hand or left-hand, the former being that which gives a cutting edge on the right, and the latter, on the left side. As the side rake is increased, the power to drive the tool along in its traversing direction becomes less, as it tends to screw its way along.

Setting the Tool

Fig. 11 illustrates an important point in setting the tool. The further the cutting edge is from the base, or support, the greater will be the spring. Where this spring is possible the point is drawn down into the work as indicated by the dotted line, and furthermore will produce irregularly-shaped work due to the variation in the resistance of the cut at points where the tool digs in. This indicates the value of short leverage. In Continental shops, and especially in England, it has become a recognized principle that the top of the cutting edge of a tool should not be higher than the top of the support, and to obtain top rake, the tool is hollowed out by grinding. Sir Joseph Whitworth designed his lathes so that the tool was set on the center of the work, and any vertical pressure deflected the tool away from the work, as shown in Fig. 12.

Next in importance to the leverage of the tool is the angle at which it is set in relation to the work. Referring now to Fig. 6, the tool is

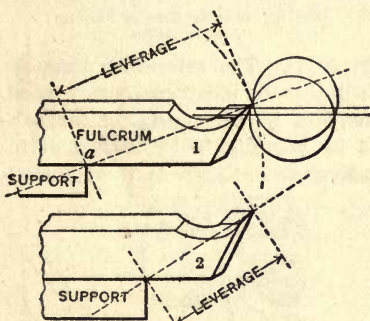

Fig. 11. Supporting the Tool in the Lathe

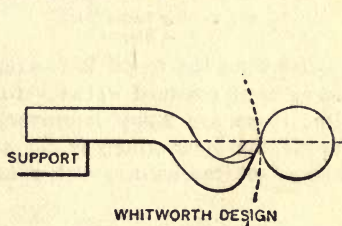

Fig. 12. Design of Tool Permitting it to Spring away from Work

shown at right angles to the work and the cutting pressure tends to force the tool around to the right, away from the work, in the direction of the arrow, instead of causing it to dig into the work. If the tool were set as shown in the dotted position, it will readily be seen that any slipping or deflection would carry it into the cut.

The third point to be observed in regard to setting the tool is its height relative to the lathe centers. Fig. 13 illustrates this. Tool No. 1 is set below the center, and the dotted line, drawn tangent to the point of the tool on the periphery of the circle, indicates the direction in which the cutting force is applied. The top or cutting surface of the tool forms an angle of 90 degrees with this line. The stock is thus merely crowded off by the tool and there is no cutting or wedge action whatever. The next tool is set on the center and has more of a wedge action, but still not what it should be. The top tool, No. 3, gives us the best cutting wedge and will do maximum work with minimum resistance. From the foregoing it is clear that the lathe tool will do the best work with combination of top and side rake, when supported near the cutting edge, held at right angles to the work, and when set about the center. This will lead to economy.

Grinding

Now a few words about grinding. The diamond point tool should be ground only on the top, and the angles on the sides should never be touched, and there will be no danger in such a case of destroying the economic value of the tool. Many mechanics burn the cutting edges of the tool in grinding, by simple carelessness, which makes the edge

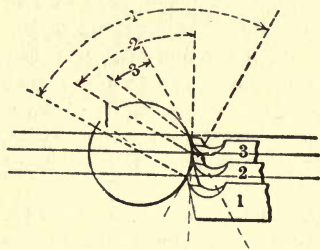

Fig. 13. Setting Lathe Tool to Correct Height

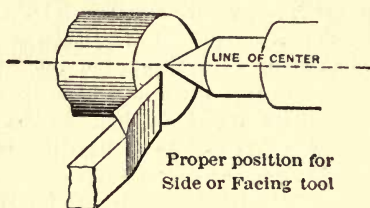

Fig. 14. Setting Side or Facing Tool in Lathe

softer than the metal it is supposed to cut. The references thus far have been confined entirely to the solid tools most commonly used. But there are many improved tool-holders in use, designed for self-hardening steel which is not affected by burning in the hands of incompetent mechanics, either in grinding or through lack of knowl-

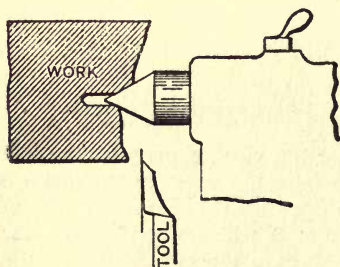

Fig. 15. Improper Bearing in Center of Work not Faced before Turning

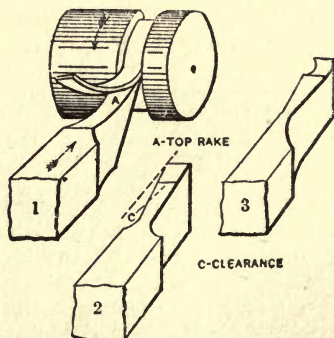

Fig. 16. Action and Form of Cutting-off Tool

edge of the proper cutting speeds. These holders support the steel in such a position as to give the proper front and side clearance, and the rake is determined by the grinding.

Speeds and Feeds

Following is a table of finishing speeds and feeds for different metals for tools of ordinary tool steel. In roughing, the axiom is slow speed and quick feed; in finishing, high speed and fine feed. From this table 25 per cent should be deducted for roughing speed, making 18, 24, 28 and 83. Experiments on cutting tools made in the shops of R. H. Smith, London, England, and verified by the author, show that machine steel requires from two to two and one-half times the power

for cutting as does cast iron, and wrought iron about one and one-half times the power. The results are given in detail in the chart, Fig. 17, which shows the increased force required for increased feed and depth of cut.

Miscellaneous Lathe Tools

The round-nose tool, Fig. 5, is used for brass, when made rather pointed, and for facing cast iron when it has a blunt point. The ten-

LATHE AND PLANER CUTTING SPEEDS AND FEEDS

Tool Steel.		Wrought Iron Machine Steel.		Cast Iron.		Brass.	
S	F	S	F	S	F	S	F
24	25	32	25	38	22	110	20
Lub.		Lub.		Dry		Dry	

F = Number of revolutions to 1 inch feed.
 S = " " " feet per minute.

dency with brass, which is very soft, would be to pull a hooked tool into the work. The side tool should always be set with the point leading slightly, but remembering that it is not the point but the side of the tool that is to do the cutting. This tool should be set on the center, as indicated in Fig. 14. Fig. 15 shows the necessity for facing

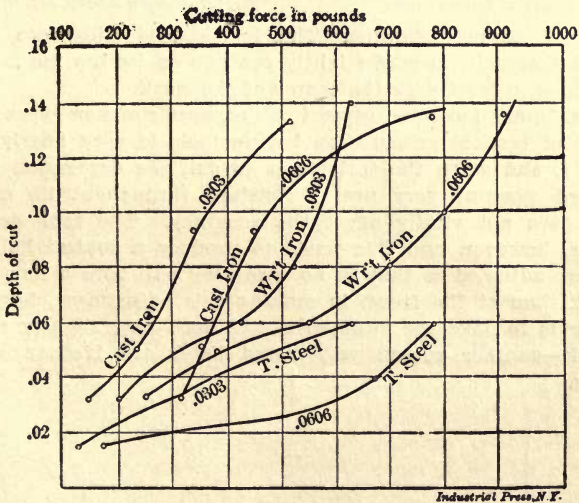

Fig. 17. Chart Showing Cutting Force Required for Increasing Feed and Depth of Cut

up work with the side tool before turning; otherwise the center will give more support to one side of the work than the other, and the pressure of the tool used later for turning will be likely to produce a crushing of the metal at the center, on the side of the least support.

The centering tool should be ground like a twist drill and placed with its cutting point directly at the center of the work and used to obtain an accurate center for starting a drill. Much carelessness is exhibited in the use of the thread-cutting tool, not so much in grinding as in setting. It should be set so that the cutting edges are directly on the line of the lathe centers and, of course, at right angles to it. The economical way to use this tool is to rough out the thread with a heavy cut, and then regrind the top surface until again sharp, and then finish with a light cut. No matter how carefully a thread tool is used the sharp point will wear rapidly.

Referring to Fig. 16, we come to the cutting-off tool, the last of the lathe tools shown in Fig. 5. The upper view shows the action of the tool and the two lower views indicate how good and poor results may

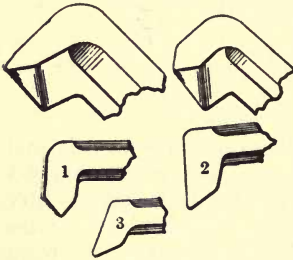

Fig. 18. Types of Boring Tools

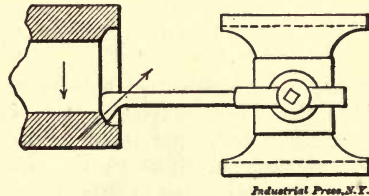

Fig. 19. Cutting Action of Boring Tools

be obtained through grinding. This tool has side clearance, right and left, and should be ground slightly concave on its top face. Its point should be on a level with the center of the work.

In Fig. 18 are indicated several of the more common types of boring tools. The vertical pressure on boring tools is very nearly constant (Fig. 19), and when the tool starts to cut, the depression or spring downward remains very nearly constant throughout its entire cut, and so does not vitally affect the accuracy. The tool wears as it advances, however, and this tends to produce a conical hole. While lathes are adjusted so that in no case they will bore a hole larger at the back than at the front, in making this adjustment, however, the tendency is to have the lathe so it will bore very slightly smaller at the back—another reason why bored holes are frequently a little tapering.

CHAPTER II

BORING TOOLS*

In the previous chapter on cutting tools we confined ourselves entirely to one class, namely, planer and lathe tools, and the different conditions under which the best results can be obtained from them. By best results is understood the maximum amount of good work with the minimum amount of energy expended—the ideal for which every good mechanic is striving. It was attempted to make plain the cardinal points for securing these results, such as proper top and side rake, clearance, rigid clamping, setting of tool so that it will not spring into the work, proper relation of cutting edge to center of work, etc. All these combine to make the cutting edge the basis of economic production, and economic production means not only least cost in manufacture, but a saving in wear and life of the machine.

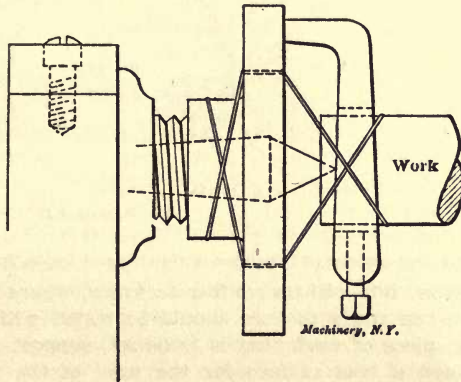

Fig. 20. Method of Holding the Work tightly against the Center

The subject of cutting tools has purposely been divided into two separate heads, as there is a recognized distinction between inside and outside turning. The rake and clearance of a tool for inside turning must be different from that used for outside turning, for two reasons: First, because of the contracted and peculiar conditions under which the boring tool works, and second, because of the spring of both tool and work—very serious conditions met with in boring which do not apply in outside turning. The spring of the work is overcome in many cases by using a steadyrest to support one end of the work while the other end is held in the chuck, or else is clamped to the faceplate and in addition is sometimes supported by the live center itself.

* MACHINERY, October, 1905.

Holding the Work tightly Against the Center

Fig. 20 may serve as a help to some who have found difficulty in keeping the work tight against the center. It shows the faceplate partly unscrewed. The lacing is made fast to a dog or carrier in that position, and the faceplate is then screwed up in place, thereby tightening the thong. Now, unless great care and skill are combined in setting the steadyrest in position, the result will be failure, because, in boring, the object is to get the bore concentric with the outside and it is a very easy matter to defeat this object by careless setting of the rest. A suggestion as to the way of setting may here be in order. If it is a piece that has already been turned on the outside, the centers may be used to good purpose. Keep the live center in the lathe spindle, screw the chuck in position and put the work on centers, as for ordinary turning. Now bring the chuck jaws down to the work and place the rest in position at the dead center end, the work all the while being still on centers. To remove the live center, the rest is then opened, the chuck, with the work in it, unscrewed, and the center

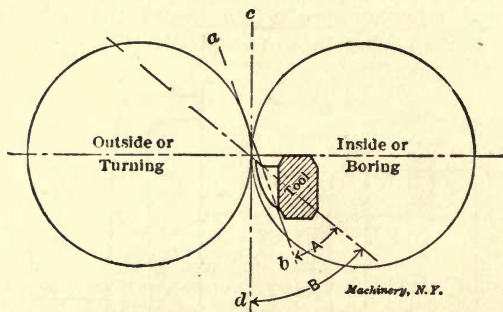

Fig. 21. Comparison of Principles of Outside and Inside Turning

removed. This method will insure fair accuracy, where it can be used, but the work when ready to bore should be tested with an indicator. If it is a rough piece of work that is to be set, support one end by the dead center, turn a true surface for the jaws of the steadyrest and place the same in position while the work is still on the center.

Difference Between Inside and Outside Turning

Fig. 21 will prove that the same laws do not hold for both inside and outside turning. The circle on the left represents a cylinder to be turned; that on the right, a hole to be bored, with the tool in position. The lines ab and cd are drawn tangent with the work at the point where the cutting edge is in contact with the work, when turning and boring respectively. On the face of it, it would seem that one vertical line should answer for both conditions, but not so, for in turning we are enabled to set the cutting edge of the tool above the center of the work, hence changing the position of the lines and getting a finer cutting wedge. The angle A is the angle of the cutting wedge in turning, while B is the angle of the cutting wedge in boring. This is the best condition obtainable in boring.

Common Type of Boring Tool

Fig. 22 shows an old-fashioned forged boring tool of the type common in every shop. These tools are forged by the tool dressed in lengths and sizes that will cover a wide range of work, so that different diameters and depths may be bored without redressing. As to results from this type of tool: When the tool starts to perform its function—takes up its cut—there is a downward spring which we call vertical deflection, due to the pressure of the chip on top of the tool. This pressure is nearly constant throughout the entire length of the cut and does not vitally affect the accuracy of the work, particularly since there can be a slight vertical movement of the tool without appreciably changing the diameter of the surface being bored. This is not the case, however, with the lateral pressure on the boring tool, which pressure, being at right angles to the cutting edge, deflects the tool away from the work more and more as the cutting edge dulls, thereby changing the angle of motion of the tool constantly. The re-

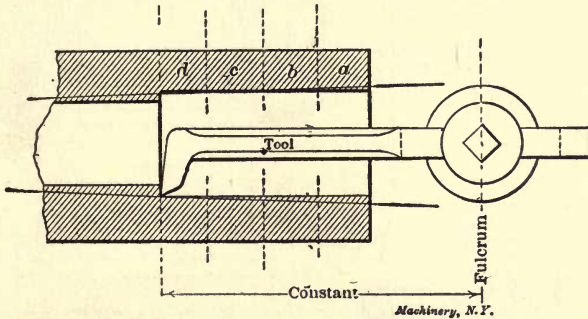

Fig. 22. Common Type of Forged Boring Tool, and Results Obtained

sult is a conical hole, and much time is lost in taking repeated cuts to get the bore parallel. This type of tool, therefore, does not prove economical, although the outward or lateral pressure will vary somewhat with the shape of the tool and the way in which it is dressed.

If the front or cutting edge makes an acute angle with the work, the lateral pressure is considerable; but if the cutting edge is at right angles to the work there is less tendency to deflect the tool in a sidewise direction. In the latter case, however, as the cutting edge wears away and the tool becomes dull, there is a tendency for the corner to become worn so as to form an acute angle and we still have some of the same trouble to contend with. Theoretically and practically, a tool ground as in Fig. 22 will give the best results, so far as cutting is concerned, but even by using the greatest care and judgment in dressing and grinding the tool, to reduce sidewise deflection, we cannot altogether remove the difficulty. This question of deflection is largely one of leverage. The amount of deflection depends upon the length of the tool from the binding screw in the toolpost to the cutting edge.

After the tool is once made, its leverage is always a constant quantity, as indicated in Fig. 22, since the tool must always be placed in

approximately the same position in the toolpost. It will, therefore, deflect as much in boring a short hole as in boring a long one, assuming the cutting edge to be in the same condition in each case. The longer the tool, the greater the deflection, for the tool is a cantilever, the deflection of which is increased eight times when its length is doubled. From this we can readily see how important is this consideration of leverage, and how desirable it is to have the boring tool adjustable so that it need project from the point of support only so far as is necessary to bore the full depth of hole required. The mechanic should try to overcome the difficulty due to leverage by devising ways and means for making the tool adjustable. Many schemes are open to the thinking mechanic.

Boring-tool Holders

Fig. 23 will give an idea for a tool-holder and for different tools which are inexpensive and at the same time meet the above require-

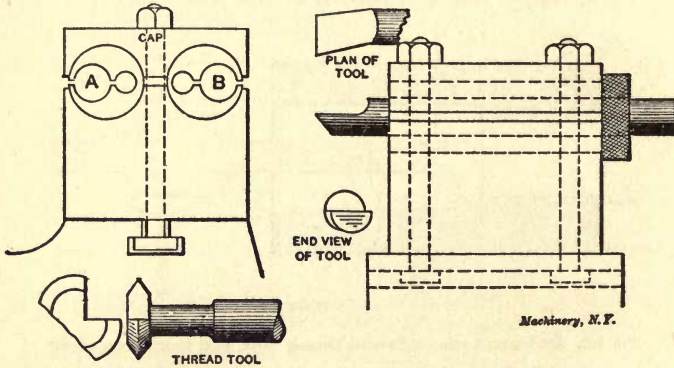

Fig. 23. Boring-tool Holder and Type of Inside Threading Tool

ment. The holder gives at all times the greatest rigidity and allows the use of the largest size of tool possible for any particular work. It also enables the operator to vary the leverage to suit each particular hole.

The holder consists of a rectangular block of cast iron in which two holes are bored, one on each side of the center, and in a plane with the lathe center, and extremely close to the edges. After this, it is sawed in two through the center of the holes, the top forming the cap. The hole may be made any standard size: $1\frac{1}{4}$, $1\frac{3}{8}$, $1\frac{1}{2}$. Into these holes are fitted sleeves or the drill rod itself, although the sleeves give wider range of size of boring tool for each holder, by having a number of sleeves with different standard size holes. The tool fits in either A or B of the sleeves. If the tool is to be used in A, a solid piece is inserted in B, so as to give a support for the cap to be clamped against. One end of the sleeve is knurled to allow for thumb and finger adjustment in raising and lowering the tool. Ordinary drill rod is used, filed down to a flat surface at the end, as shown. When heating for the tempering process, set over the filed end

by a blow of a hammer for clearance. A tool nearly the size of the hole to be bored may be used. For instance, an 11/16-inch tool could easily be used to bore a 3/4-inch hole. A thread tool of this type is of the greatest advantage in that the tool is always level—the requisite for a true-angle thread.

The good features of this type of tool are: first, it saves expense in forging; second, it saves time in grinding and setting, and in bor-

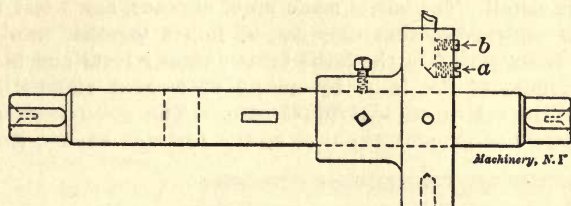

Fig. 24. Simple Type of Boring Bar

ing a true hole; third, it requires less skill and judgment in getting results. As the work increases in weight and size, and it is not practicable to clamp either on faceplate or chuck, the boring bar is substituted, in which case the former conditions are not encountered.

Boring Bars

Many styles of boring bars are used, the one shown in Fig. 24 being possibly one of the simplest type. In the boring bar head one has to consider only the proper cutting edge of the tool; and attention

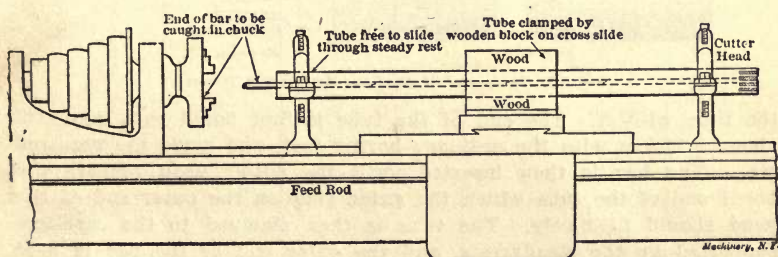

Fig. 25. Boring out Tubes

is to be called chiefly to the method of setting out the tool for increasing the depth of cut. The tool itself has a wedge end, and the set-screw *a* a conical end bearing against it, thus forcing the cutter out as the screw moves in. The binding screw *b* comes in contact with a flat side filed or ground on the cutter. Heads of different sizes are made to fit the bar, to suit holes of different diameters, insuring a short tool leverage. There are many improvements possible in this bar, such, for instance, as feeding the tool head by means of a screw carried in the bar and receiving its rotary motion from a stationary gear on the dead center spindle engaging with a gear on the end of the screw.

Boring out Tubes

In many cases it is desirable to bore holes of small diameter but of great length which extend through the entire length of a tube, such for example, as core barrels for rock drilling, where the tube is from 10 to 14 feet long, and as small in some cases as 2 inches in diameter. Fig. 25 will give an idea of the method by which such holes may be bored with very satisfactory results, and in Fig. 26 the boring bar is shown in detail. The bar is made up of sections, say 3 feet long, the sections so constructed that they can be joined together into one bar. The work is supported in the lathe by two steady rests and is clamped to the carriage of the lathe by means of wooden clamps, specially constructed to suit each individual case. The steadyrests are only used to guide and support the tube as the carriage advances, carrying

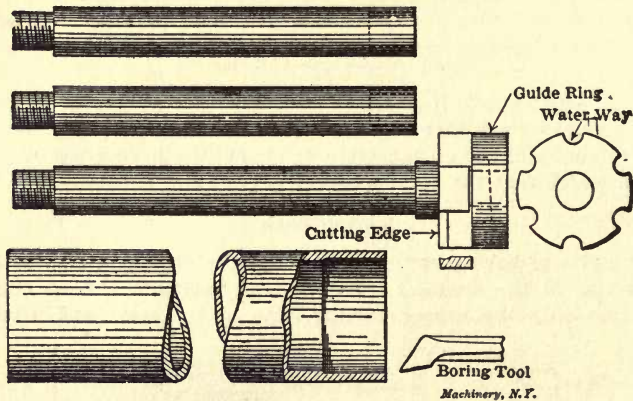

Fig. 26. Tools and Method for Boring out Tubes

the tube with it. The end of the tube is first bored to a depth of about 2 inches with the ordinary boring tool, and made the required size. The bar is then inserted until the cutter head reaches the bored end of the tube which the guide ring on the outer end of the head should fit nicely. The tube is then clamped to the carriage, supported by the steadyrests, and the outer end of the bar is held by the lathe chuck. Allowance should be made for the tube to travel a distance equal to the entire length of one of the boring bar sections. When the tube has advanced this far, one of the sections of the bar is unscrewed and laid aside and the chuck engages the end of the next section, and so the work proceeds until completed. It should be observed that the face only of the tool should be used as a cutting edge, while the outside acts simply as a guide.

CHAPTER III

FORGING LATHE BORING TOOLS*

Cold shuts, the starting point of the water cracks so often found in lathe tools, may be caused by heating the steel too quickly or too slowly. In heating too quickly, the center of the bar does not reach the same degree of heat as the outside of the bar, and consequently the outside part of the bar draws out under the hammer more freely than the center, thus causing a parting of the metal. This is the starting point for a water crack when hardening the tool. Heating a tool too slowly, and exposing it to the air either at the top or bottom, decarbonizes the steel, and a poor lathe tool may be the result.

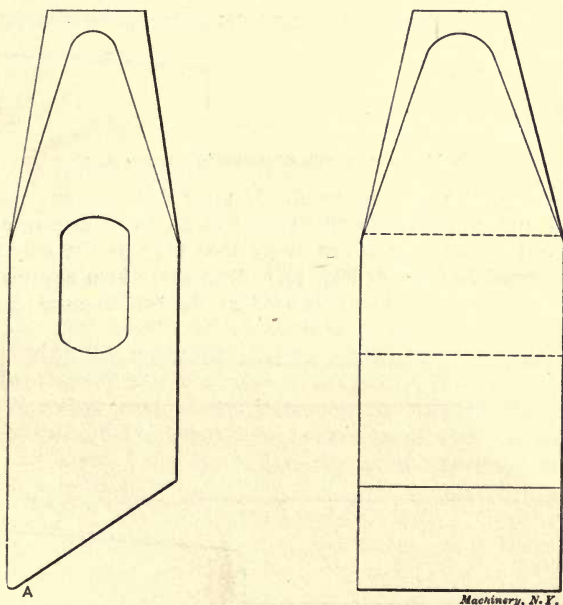

Fig. 27. Bevel Set

When heating tool steel a heavy fire should be used, a good solid foundation of coke being laid in the bottom of the fire, and the steel should be well covered with coke. The smith must watch the steel carefully, and not allow it to remain in the fire and "soak," as is sometimes the case, especially if he has struck a position that is restful, or has started an earnest conversation with his working mate.

* MACHINERY, September, 1907.

When forging a boring tool, a bevel set should be used of the form shown in Fig. 27, having a round corner at *A*. After heating the steel, drive the set down, making a "V," as shown at *A*, Fig. 28. The rounded corner forms the fillet at the bottom. Some smiths use a large top fuller for making the "V," but the result is a clumsy round cor-

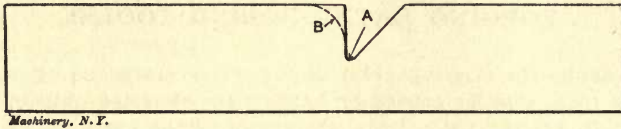

Fig. 28. Characteristic "V" made by Set

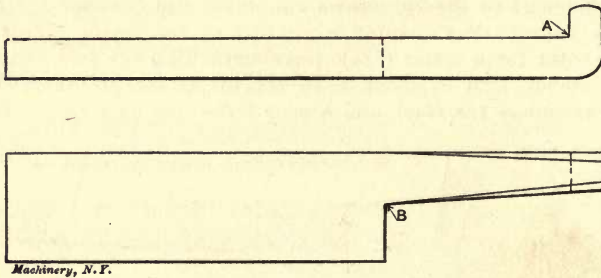

Fig. 29. Tool Blank with Objectionable Sharp Angles

ner as shown by the dotted line *B*. If after drawing out the stem of the tool we turn over the lip on the end of an anvil having sharp corners, we shall get another sharp angle that may be the starting point for a water crack. (See *A*, Fig. 29.) The same also applies to angle *B*, lower view, Fig. 29. The anvil used by the tool dresser should have

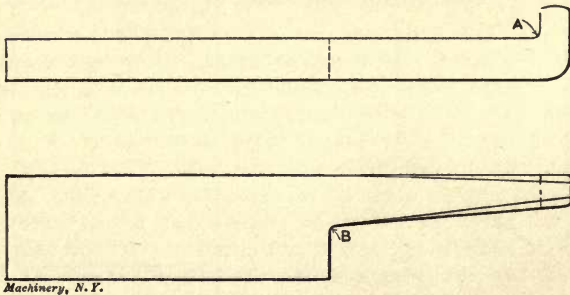

Fig. 30. Tool Blank with Form of Fillets to be Provided

round corners for about four inches from the square end on both sides. Then, when forging a tool that should have fillets in place of the sharp corners as shown at *A* and *B*, Fig. 30, the means are at hand for forming them. Never use a chisel on a lathe tool if it can be avoided.

When about to lengthen out the stem on a boring tool, it is a common practice to heat the tool to a lemon heat, and with a chisel chop

out a piece at *A*, Fig. 31, thus leaving the tool marred by chisel marks that cannot be removed by hammering. Now, when the tool is used up to that part, it cracks every time it is put in the water. The proper way to lengthen a boring tool is as shown in Fig. 32. Drive the bevel set down as at *A*, then cut off the corner *B*, and draw out the stem to the proper length and size. If a boring tool has a fairly good lip and has to be lengthened in the stem, give the stem a half twist after lengthening, and the job is completed.

A common mistake a great many smiths make when tempering or hardening a boring tool is to heat the tool a little too hot, and dip the end into fresh water to a point just above the lip, and hold it still

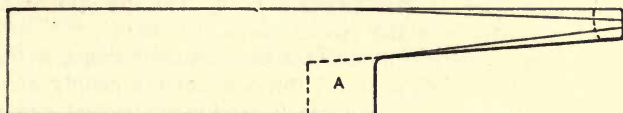

Machinery, N. Y.

Fig. 31. Bad Practice in Lengthening a Boring Tool Stem

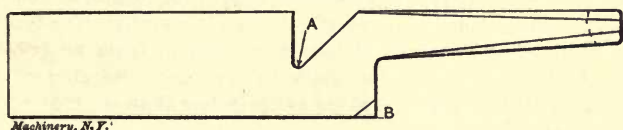

Machinery, N. Y.

Fig. 32. Recommended Practice for Lengthening a Boring Tool Stem

until it is cold. This is bad practice. In the first place the tool dresser should use salt water for hardening all kinds of tools, for the tools will harden at a much lower heat, and this will do away with cracking. In the second place the tool should be moved around in the water constantly until ready to be removed.

An inside threading tool should be forged in the same way as the boring tool, except that, when trimming off the cutting part, it is shaped differently, being brought to a sharp point with clearance below. It should be tempered the same, however, as the boring tool, but will not stand to be quite so hard.

CHAPTER IV

SHAPE OF STANDARD SHOP TOOLS

The data relating to the proper shape of standard shop tools, and the tables of cutting speeds and feeds, given in this and the following chapter, are the results of experiments undertaken during a long period of years by Mr. Fred W. Taylor. The present chapter is an abstract of that part of Mr. Taylor's work, "On the Art of Cutting Metals," which deals with the proper shape of tools.

In Mr. Taylor's practical experience in managing shops, he found it no easy matter to maintain at all times an ample supply of cutting tools ready for immediate use by each machinist, treated and ground so as to be uniform in quality and shape; and the greater the variety in the shape and size of the tools, the greater became the difficulty of keeping always ready a sufficient supply of uniform tools. His whole experience, therefore, points to the necessity of adopting as small a number of standard shapes and sizes of tools as practicable. It is far better for a machine shop to err upon the side of having too little variety in the shape of its tools rather than on that of having too many shapes.

Standard Tools*

In the engravings Figs. 33 to 44, inclusive, are shown the shapes of the standard tools which Mr. Taylor adopted, and in justification of his selection he states that these tools have been in practical use in several shops, both large and small, through a term of years, and are giving general, all-round satisfaction. It is a matter of interest also to note that in several instances changes were introduced in the design of these tools at the request of some one foreman or superintendent, and after a trial on a large scale in the shop of the suggested improvements, the standards as illustrated here were again returned to. These shapes may be said, therefore, to have stood the test of extended practical use on a great variety of work.

Elements Considered in Adopting Standard Tools

These standard tools may be said to represent a compromise in which each one of the following elements has received most careful consideration, and has had its due influence in the design of the tool; and it can also be said that hardly a single element in the tools is such as would be adopted if no other element required consideration. The following, broadly speaking, are the four objects to be kept in mind in the design of a standard tool:

- a. The necessity of leaving the forging or casting to be cut with a true and sufficiently smooth surface;
- b. The removal of the metal in the shortest time;

* MACHINERY, March, 1907.

c. The adoption of that shape of tool which shall do the largest amount of work with the minimum combined cost of grinding, forging and tool steel;

d. The ready adaptability to a large variety of work.

As we go further into this subject, the nature of the conflict between these four objects and of the sacrifice which each element is called upon to make by one of the others will become apparent. Generally speaking, it is necessary to adopt as our standard shape a tool which can be run at only about, say, five-eighths of the cutting speed which the knowledge of the art and the experiments show could be obtained through another tool of entirely different shape, if no other element than that of cutting speed required consideration. It becomes necessary to sacrifice cutting speed to securing smaller liability to chatter; a truer finish; a greater all-round convenience for the operator in using the tool, and a comparatively cheaper dressing and grinding.

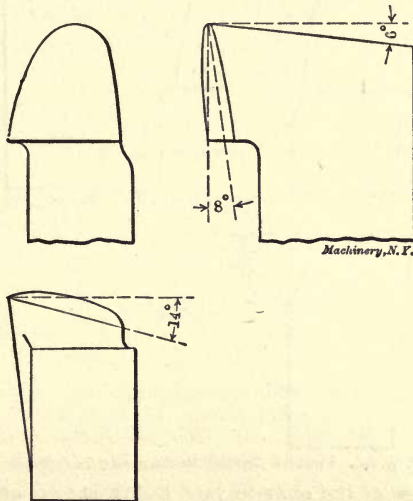

Fig. 33. Tool for Cutting Cast Iron and Hard Steel

The most important of the above considerations, however, is the freedom from chatter.

On the other hand, it is necessary to adopt a rather more elaborate and expensive method of dressing the tools than is usual, in order to provide a shape of tool which allows it to be ground a great many times without redressing, and also in order to make a single Taylor-White heat treatment of the tool last longer than it otherwise would. And again, the shape of the curve of the cutting edge of the tool adopted—first, to insure against chatter, and second, for all-round adaptability in the lathe—calls for much more expense and care in the grinding than would be necessary if a more simple shape were used. This necessitates in a shop either a specially trained man to grind the tool by hand to the required templets and angles, or preferably the use of an automatic tool grinder.

Relative Importance of the Elements Affecting the Cutting Speed

The cutting speed of a tool is directly dependent upon the following elements. The order in which the elements are given indicates their relative effect in modifying the cutting speed, and in order to compare them, we have given in each case figures which represent, broadly speaking, the ratio between the lower and higher limits of speed as affected by each element.

A. The quality of the metal which is to be cut, *i.e.*, its hardness or other qualities which affect the cutting speed.) Proportion is as 1 in the case of semi-hardened steel or chilled iron, to 100 in the case of very soft low-carbon steel.

B. The chemical composition of the steel from which the tool is made, and the heat treatment of the tool.) Proportion is as 1 in tools made from tempered carbon steel, to 7 in the best high-speed tools.

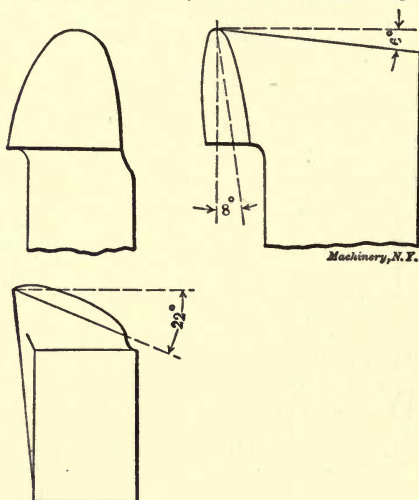

Fig. 34. Tool for Cutting Medium and Soft Steel

C. The thickness of the shaving; or, the thickness of the spiral strip or band of metal which is to be removed by the tool, measured while the metal retains its original density; not the thickness of the actual shaving, the metal of which has become partly disintegrated. Proportion is as 1 with thickness of shaving $\frac{3}{16}$ of an inch, to $3\frac{1}{2}$ with thickness of shaving $\frac{1}{64}$ of an inch.

D. The shape or contour of the cutting edge of the tool, chiefly because of the effect which it has upon the thickness of the shaving.) Proportion is as 1 in a thread tool, to 6 in a broad-nosed cutting tool.

E. Whether a copious stream of water or other cooling medium is used on the tool.) Proportion is as 1 for tool running dry, to 1.41 for tool cooled by a copious stream of water.

F. The depth of the cut; or, one-half of the amount by which the forging or casting is being reduced in diameter in turning.) Proportion is as 1 with $\frac{1}{2}$ -inch depth of cut, to 1.36 with $\frac{1}{8}$ -inch depth of cut.

G. The duration of the cut; *i.e.*, the time which a tool must last under pressure of the shaving without being reground.) Proportion is as 1 when tool is to be ground every $1\frac{1}{2}$ hour, to 1.207 when tool is to be ground every 20 minutes.

H. The lip and clearance angles of the tool.) Proportion is as 1 with lip angles of 68 degrees, to 1.023 with lip angle of 61 degrees.

J. The elasticity of the work and of the tool on account of producing chatter.) Proportion is as 1 with tool chattering, to 1.15 with tool running smoothly.

The quality of the metal which is to be cut is, generally speaking, beyond the control of those who are in charge of the machine shop, and, in fact, in most cases the choice of the hardness of metals to be used in forgings or castings will hinge upon other considerations which are of greater importance than the cost of machining them. The chemical composition of the steel from which the tool is made and the heat treatment of the tool will, of course, receive the most careful consideration in the adoption of a standard tool. No shop, however,

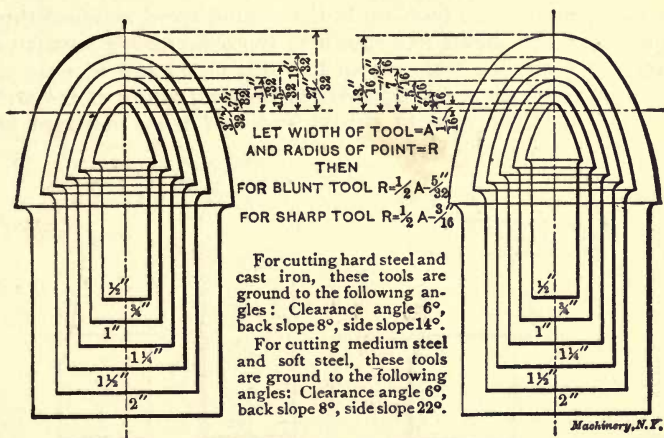

Figs. 35 and 36. Outline of Cutting Edge of Standard Round-nosed Tools

can now afford to use other than the "high-speed" tools, and there are so many makes of good tool steels, which, after being forged into tools and heated to the melting point according to the Taylor-White process, will run at about the same high cutting speeds, that it is of comparatively small moment which particular make of high-speed steels is adopted.

Advantages of Round-nosed Tools

With round-nosed tools, as the depth of cut becomes more shallow, there is a greater increase in the cutting speed than in the case of tools having straight-line cutting edges, because with a round-nosed tool the thickness of the shaving becomes thinner as the extreme nose of the tool is approached. In the case of round-nosed tools, therefore, when the depth of the cut is diminished, the cutting speed is increased for two entirely different reasons:

A. Because the chip bears upon a smaller portion of the cutting edge of the tool.

B. Because the average thickness of the chip which is being removed is thinner in the case of round-nosed tools with a shallow depth of cut than it is with the deeper cuts.

Object of Having the Cutting Edge of Tools Curved

A tool whose cutting edge forms a curved line of necessity removes a shaving which varies in its thickness at all parts. The only type of tool which can remove a shaving of uniform thickness is one with a straight-line cutting edge. The object in having the line of the cutting edge of a roughing tool curved as that part of the cutting edge which does the finishing is approached, is to thin down the shaving at this point to such an extent as will insure the finishing part of the tool remaining sharp and uninjured even though the main portion of the cutting edge may have been ruined through over-heating or from some other cause.

Advantages and Disadvantages of Broad-nosed Tools

Upon appreciating the increase in the cutting speed obtained through thinning down the shaving as shown in the experiments with straight cutting edge tools, the tools shown in Figs. 45, 46 and 48 were made, and used on roughing work for years in the axle lathes of the Midvale Steel Company. The gain in cutting speed of these standard broad-

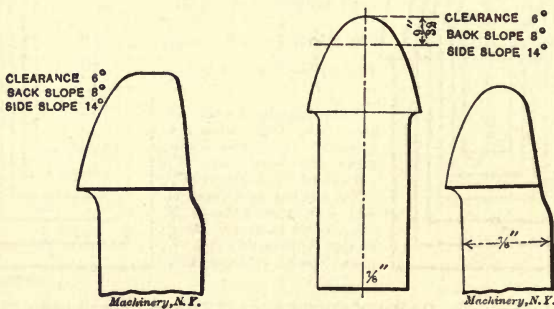

Fig. 37. Standard Tool for Wide Feeds

Fig. 38. Tool used in most of the Taylor Experiments

nosed tools over our standard round-nosed tools, shown in Figs. 37 and 38, is in the ratio of 1.30 : 1. This general shape of tool continues to be extensively used, but it is subject to the disadvantage that it is likely to cause the work to chatter, and so leave a more or less irregular finish. Were it not for this difficulty, added to the fact that the standard round-nosed tool has a greater all-round adaptability and convenience, the tools illustrated in Figs. 45, 46 and 48 would undoubtedly be the proper shapes for shop standards.

Influence of Small Radius of Curvature on Chatter

Since the thickness of the shaving is uniform with straight edge tools, it is evident that the period of high pressure will arrive at all points along the cutting edge of this tool at the same instant and will be followed an instant later by a corresponding period of low pressure; and that when these periods of maximum and minimum pressure approximately correspond to, or synchronize with the natural periods of vibration either in the forging, the tool, the tool support, or in any part of the driving mechanism of the machine, there will be a resultant

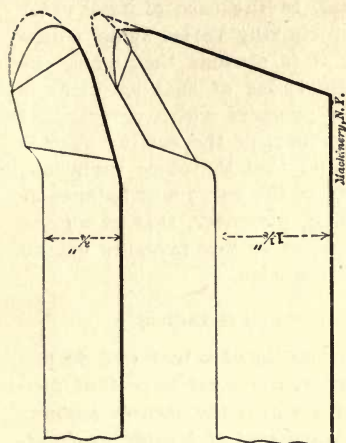

Fig. 41

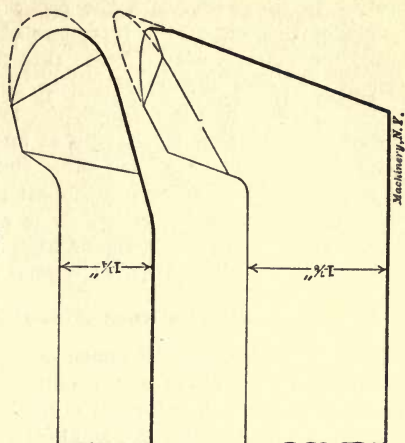

Fig. 44

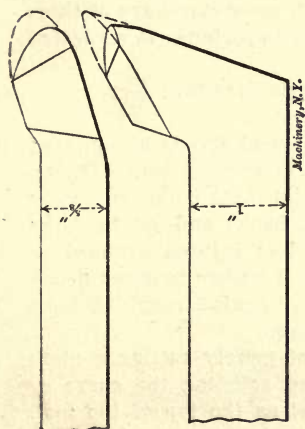

Fig. 40

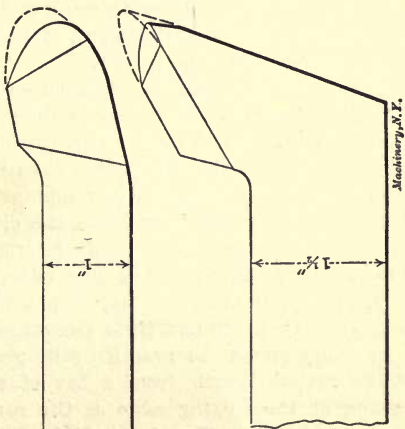

Fig. 43

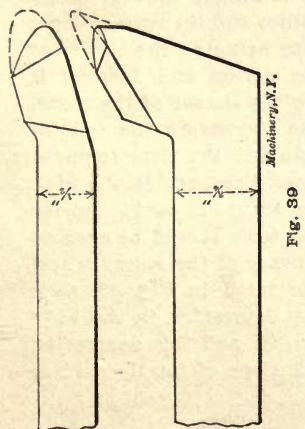

Fig. 39

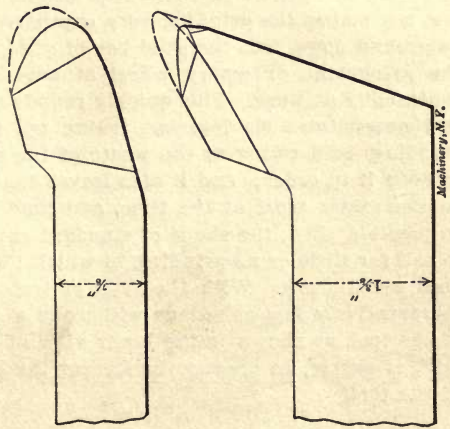

Fig. 42

chatter in the work. On the other hand, in the case of tools with curved cutting edges, the thickness of the shaving varies at all points along the cutting edge. From this fact it is obvious that when the highest pressure corresponding to one thickness of shaving along a curved cutting edge is reached, the lowest pressure which corresponds to another thickness of shaving at another part of the cutting edge is likely to occur at about the same time, and that therefore variations up and down in pressure at different parts of the curve will balance or compensate one for the other. It is evident, moreover, that at no one period of time can the wave of high pressure or low pressure extend along the whole length of the curved cutting edge.

Relation Between Cost of Forging and Grinding

In adopting the general shape or conformation of a tool (we do not here refer to the curve of the cutting edge), the most important consideration is that of selecting a shape with which the largest amount of work can be done for the smallest *combined cost of forging or dressing and grinding*, and the dressing is the much more expensive of these two operations. It is, therefore, of paramount importance to so design the tool that it can be ground:

- a. The greatest number of times with a single dressing;
- b. With the smallest cost each time it is ground.

Modern high-speed tools when run at economical speeds are injured much more upon the lip surface than upon the clearance flank. Therefore, at each grinding a larger amount of metal must be ground away from the lip surface than from the clearance flank; and yet in many cases the clearance flank will be more or less injured (rubbed or scraped away) below the cutting edge, and it therefore becomes necessary, for maximum economy, in practical use, to grind roughing tools both upon their lip and their clearance surfaces.

In many shops the practice still prevails of merely cutting a piece of the proper length from a bar of steel and grinding the curve or outline of the cutting edge at the same level as the top of the tool, as shown in Figs. 47 and 49. This entails the minimum cost for dressing, but makes the grinding very expensive, since the lip surface must be ground down into the solid bar of steel, thus bringing the corner of the grindstone or emery wheel at once into action and keeping it continually at work. This quickly rounds over the corner of the stone, and necessitates its frequent truing up, thus increasing the cost of grinding, both owing to the waste of the stone and the time required to keep it in order; and it also leaves the face of the grindstone high in the center most of the time, and unfit for accurate work. As far as possible, then, the shape of standard cutting tools should be such as to call for little or no grinding in which the corner of the emery wheel does much work. With the type of tool illustrated in Fig. 49, also, comparatively few grindings will make a deep depression in the body of the tool, as shown in the lower view of Fig. 50, and this depression will, of course, be greater the steeper the back slope of the lip surface of the tool.

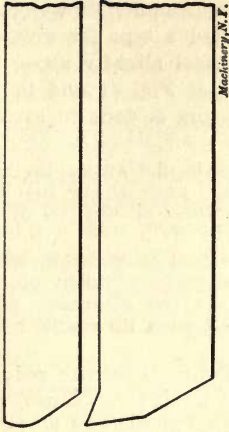
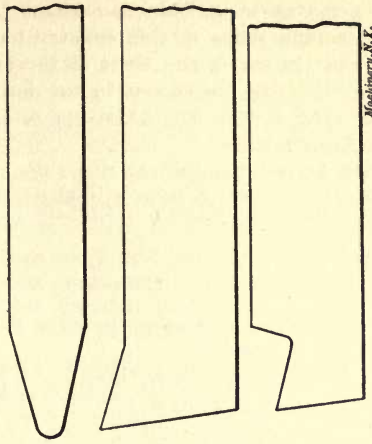
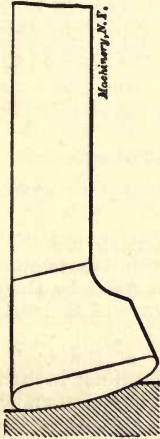

Fig. 47. Common, but Objectionable Way of Dressing Tools



Figs. 49 and 50. Incorrectly Dressed Tools



Figs. 45 and 46. Examples of Broad-nosed Tools

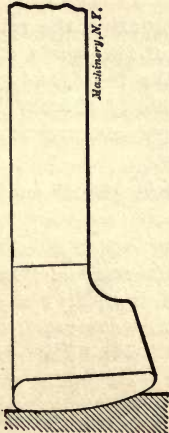

Machinery, N. E.

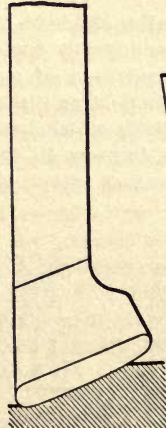

Machinery, N. E.



Fig. 48. Example of Broad-nosed Tool

Machinery, N. E.

To avoid these difficulties, perhaps the larger number of well-managed machine shops in this country have adopted a type for dressing their tools in which the front of the tool is forged slightly above the level of the tool, as shown in the lower view of Fig. 47 and in the middle view of Fig. 50. This type of tool dressing is done in each of the following ways:

A. By laying the tool on its side and slightly flattening its nose by striking it with a sledge, thus narrowing the nose of the tool and at the same time raising it slightly above the level of the top of the tool.

B. By cutting off the clearance flank of the tool at a larger angle than is demanded for clearance, and then slightly turning up the cutting edge of the tool through sledging upon the clearance flank while the tool is held upon the edge of the anvil with its shank below the level of the anvil.

The objection to both of these types is that the tools require redressing after being ground a comparatively small number of times, and that when redressed, in many cases the whole nose of the tool is cut off and thrown away. This waste of metal, however, is of much less consequence than the frequency of dressing. With the first of these types of tool dressing the tendency is to make the nose of the tool too thin, that is, having too small a radius of curvature, and thus to furnish a tool which must be run at too slow a cutting speed.

Length of Shanks of Cutting Tools*

In choosing the proper lengths for cutting tools, we again find two conflicting considerations:

A. It requires a certain very considerable length for the shank of the cutting tool in order to fasten or clamp it in its toolpost. When the tool becomes shorter than this minimum, it must be thrown away, thus wasting costly metal, particularly in the case of the modern high-speed tools.

B. On the other hand, the longer the body of the tool, the more awkward and the slower become all of the operations in handling the tool, beginning with the dressing and followed by the grinding, storing, handling in the tool-room, and setting and adjusting in the machine.

There is no definite, clear-cut method of comparing the relative loss in handling long and heavy tools with that of the waste of the tool steel, so that the adoption of standard lengths for dressing tools of various sizes has been largely a matter of "rule of thumb" judgment, and the length of tools which have been adopted, corresponding to different sized bodies, is given in the table below.

Let width of shank of tool = A , and length of tool = L ; then $L = 14A + 4$ inches.

Size of Shank of Tool, inches.	Length of Tool, inches.	Size of Shank of Tool, inches.	Length of Tool, inches.	Size of Shank of Tool, inches.	Length of Tool, inches.
$\frac{1}{2} \times \frac{3}{4}$	11	$\frac{7}{8} \times 1\frac{3}{8}$	16 $\frac{1}{4}$	$1\frac{1}{2} \times 2\frac{1}{4}$	25
$\frac{5}{8} \times 1$	12 $\frac{3}{4}$	$1 \times 1\frac{1}{2}$	18	$1\frac{3}{4} \times 2\frac{5}{8}$	28 $\frac{1}{2}$
$\frac{3}{4} \times 1\frac{1}{4}$	14 $\frac{1}{2}$	$1\frac{1}{4} \times 1\frac{7}{8}$	21 $\frac{1}{2}$	2×3	32

* MACHINERY, April, 1907.

CHAPTER V

CUTTING SPEEDS AND FEEDS FOR LATHE TOOLS*

A study of the effect of the feed and depth of cut upon the cutting speed constitutes the most important element in the art of cutting metals. The three questions which must be answered each day in every machine shop by every machinist who is running a metal cutting machine, such as a lathe, planer, etc., are:

What tool shall I use?

What cutting speed shall I use?

What feed shall I use?

Having in the previous chapter already given the standards for the shape and quality of the tools, there remain but two of these questions to be answered, namely, those relating to the cutting speed and the feed; and the decision as to the cutting speed will depend more upon the depth of cut and feed which are chosen than upon any other element.

In the accompanying tables,† pages 30 to 33, inclusive, are given practical working data which will be found useful by machine shop foremen and machinists as a general guide in determining what cutting speed to use under several of the usual or typical conditions met with in ordinary machine shop practice. The cutting speeds given here are based upon the use of standard tools for cutting hard steel and cast iron as well as for cutting medium and soft steel. In preparing these tables the use of the best quality of high-speed steel tools, treated in the best manner, was assumed. The tables were also based upon cutting three different qualities of steel, and the following cutting speeds when cut with standard $\frac{7}{8}$ -inch tool, $\frac{3}{16} \times \frac{1}{16}$ -inch, for standard 20-minute cut.

Hard steel: (such for instance as is used in a hard locomotive tire), cutting speed, 45 feet per minute.

Medium steel: cutting speed, 99 feet per minute.

Soft steel: cutting speed, 108 feet per minute.

The tables made out for cutting cast iron are based upon three qualities of cast iron representative of hard, medium and soft cast iron as ordinarily found in the average machine shop in this country. In each shop, however, accurate experiments should be made to determine the average cutting speeds of the cast iron actually used. It is more difficult to predict the correct cutting speed for cast iron than for steel. The physical properties of steel constitute a fairly accurate guide to its cutting speed; and these properties are best indicated by the tensile strength and percentage of stretch and contraction of area obtained from standard tensile test bars cut from such a position in the body of the forging as to represent its average quality, and then broken in a testing machine.

* MACHINERY, August, 1907.

† From MACHINERY'S Data Sheet No. 72, August, 1907.

$\frac{1}{64}$	370	185	84.1
$\frac{1}{32}$	260	130	59.1
$\frac{1}{16}$	183	91.7	41.6
$\frac{3}{32}$	149	74.6	33.8
$\frac{1}{8}$	129	64.5	29.3
$\frac{5}{16}$	105	52.6	23.8
$\frac{3}{8}$	82	41.6	18.3
$\frac{1}{2}$	64	33.8	14.9
$\frac{3}{4}$	52.6	29.3	12.9
$\frac{7}{8}$	41.6	23.8	10.5
1	33.8	18.3	8.2
$\frac{1}{16}$	159	79.7	36.1
$\frac{1}{8}$	130	65.0	29.5
$\frac{3}{16}$	112	56.1	25.5
$\frac{1}{4}$	91.4	45.7	20.8
$\frac{3}{8}$	74.6	37.0	17.0
$\frac{1}{2}$	64.5	31.9	14.9
$\frac{3}{4}$	56.1	27.8	13.0
1	45.7	23.8	11.2
$\frac{1}{16}$	230	115	52.3
$\frac{1}{8}$	162	80.9	36.8
$\frac{3}{16}$	114	56.9	25.9
$\frac{1}{4}$	82.6	46.3	21.0

Standard 1-inch Tool

$\frac{1}{64}$	490	245	111
$\frac{1}{32}$	339	169	77.0
$\frac{1}{16}$	235	117	53.4
$\frac{3}{32}$	189	94.5	43.0
$\frac{1}{8}$	142	71.0	32.3
$\frac{5}{16}$	102	50.7	23.8
$\frac{3}{8}$	83.0	41.6	18.3
$\frac{1}{2}$	68.8	34.4	15.5
$\frac{3}{4}$	58.9	29.3	13.0
1	48.3	24.2	11.2

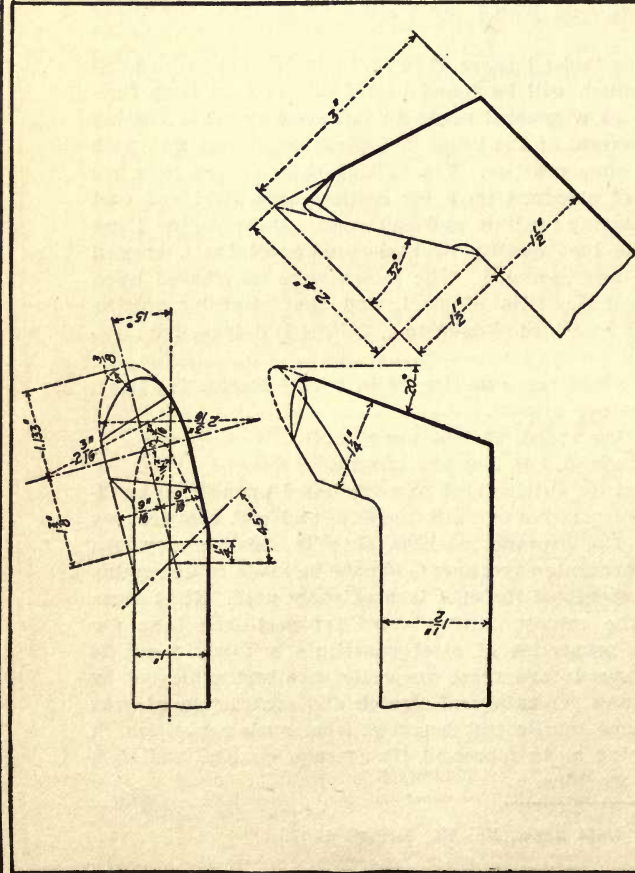

Detailed Dimensions of 1-inch Round Nose Roughing Tool. Forged Outline shown by Dotted Lines and Ground Form by Full Lines. Clearance, 6 degrees; Back slope, 8 degrees, and Side Slope 14 degrees.

$\frac{3}{32}$	366	183	83.2
$\frac{1}{8}$	257	129	58.4
$\frac{3}{16}$	209	105	47.5
$\frac{1}{4}$	157	78.5	35.7
$\frac{3}{8}$	129	64.5	29.3
$\frac{1}{2}$	102	50.7	23.8
$\frac{3}{4}$	83.0	41.6	18.3
1	68.8	34.4	15.5

Standard $\frac{1}{4}$ -inch Tool						
Depth of Cut in inches	Cutting Speed, in feet per minute for a tool which is to last 1 hour and 30 minutes before regrinding					
	<table border="1"> <tr> <td>Soft Steel</td> <td>Medium Steel</td> <td>Hard Steel</td> </tr> <tr> <td>518</td> <td>259</td> <td>118</td> </tr> </table>	Soft Steel	Medium Steel	Hard Steel	518	259
Soft Steel	Medium Steel	Hard Steel				
518	259	118				

Standard 1/8 inch Tool		Standard 3/8 inch Tool	
1/16	64	548	274
3/32	32	358	179
1/8	16	235	117
5/32	8	467	234
3/16	6	306	153
1/4	4	200	100
5/16	3	156	78.0
3/8	2	417	209
7/16	1.5	273	136
1/2	1	179	89.3
5/8	0.75	140	69.8
3/4	0.6	362	181
7/8	0.45	236	118
1	0.35	155	77.4
		328	164
		215	107
		286	143

Standard 1/2 inch Tool		Standard 1 inch Tool	
1/10	64	510	255
3/20	32	322	161
1/8	16	203	102
3/16	10	445	223
1/4	8	281	141
5/16	6	177	88.7
3/8	4.5	135	67.4
7/16	3.5	404	202
1/2	2.5	255	128
5/8	1.8	161	81
3/4	1.4	359	179
7/8	1	226	113
1	0.75	330	165

Standard 1/4 inch Tool		Standard 3/4 inch Tool	
3/10	64	352	176
1/4	32	240	120
5/16	16	164	82
3/8	10	131	65.5
7/16	8	112	56.0
1/2	6	312	156
5/8	4.5	213	107
3/4	3.5	145	72.6
7/8	2.5	116	58.1
1	1.8	264	132
5/8	1.4	180	90.2
3/4	1	122	61.1
7/8	0.75	237	118
1	0.6	162	80.8

Standard 1/2 inch Tool		Standard 1 inch Tool	
3/10	64	482	241
1/4	32	323	161
5/16	16	217	109
3/8	10	172	85.8
7/16	8	423	212
1/2	6	284	142
5/8	4.5	190	95.2
3/4	3.5	151	75.3
7/8	2.5	128	63.8
1	1.8	358	179
5/8	1.4	240	120
3/4	1	161	80.5
7/8	0.75	127	63.7
1	0.6	320	160
5/8	0.45	215	107
3/4	0.35	144	72
7/8	0.25	276	138
1	0.18	185	92.4

Standard 1 inch Tool (Continued)		Cutting Speed in feet per minute for a tool which is to last 1 hour and 30 minutes before re-grinding		
Depth of Cut in Inches	Feed in Inches	Soft Steel	Medium Steel	Hard Steel
		1/16	171	88.5
3/32	3/32	133	69.0	31.3
1/8	1/8	118	59.0	26.8
5/32	5/32	95.0	47.5	21.6
3/16	3/16	81.5	41.5	17.6
1/4	1/4	71.5	37.5	15.7
5/16	5/16	64.5	34.5	14.5
3/8	3/8	59.5	31.5	13.5
1/2	1/2	55.7	28.5	12.5
5/8	5/8	52.0	26.5	11.5
3/4	3/4	49.5	24.5	10.5
7/8	7/8	47.5	23.5	10.0
1	1	45.5	22.5	9.5

Standard 1/8 inch Tool		Standard 3/8 inch Tool	
3/10	64	476	238
1/4	32	325	162
5/16	16	222	111
3/8	10	177	88.4
7/16	8	420	210
1/2	6	286	143
5/8	4.5	195	97.6
3/4	3.5	156	77.9
7/8	2.5	133	66.4
1	1.8		30.2

Standard 1/4 inch Tool		Cutting Speed in feet per minute for a tool which is to last 1 hour and 30 minutes before regrinding		
Depth of Cut in Inches	Feed in Inches	Soft Cast Iron	Medium Cast Iron	Hard Cast Iron
		3/32	1/64	239
	3/32	191	95.3	55.6
	1/16	142	70.8	41.3
	3/32	118	59.1	34.4
	1/8	103	51.1	30.2
	3/16	85.0	42.5	24.8
	1/4	210	108	63.1
	3/16	172	86.2	50.3
	1/8	128	64.0	37.3
	3/32	107	53.4	31.2
	1/16	93.4	46.7	27.3
	3/16	76.8	38.4	22.4
	1/4	187	93.5	54.6
	3/16	149	74.6	43.6
	1/8	111	55.5	32.7
	3/32	92.5	46.3	27.0
	1/16	73.1	36.5	21.3
	3/16	66.4	33.2	19.4
	1/4	168	84.1	49.1
	3/16	134	67.2	39.2
	1/8	99.8	49.9	29.1
	3/32	83.2	41.6	24.3
	1/16	72.0	36.3	21.2
	3/16	59.7	29.8	17.4
	1/4	144	71.8	41.9
	3/8	115	57.3	33.4

3/16	85.1	42.6	24.8
1/8	70.9	35.5	20.7
3/32	62.0	31.0	18.1
1/16	51.0	25.5	14.9
3/64	131	55.6	38.3
1/32	105	52.3	30.5
3/64	77.6	38.8	22.7
1/16	64.7	32.4	18.9
3/32	56.6	28.3	16.5
1/8	46.5	23.3	13.6
3/16	112	56.0	32.7
1/4	89.2	44.6	26.0
3/32	66.2	33.1	19.3
1/16	55.2	27.6	16.1
3/64	48.3	24.2	14.1
1/32	39.7	19.8	11.6

Standard 1/2 inch Tool			
3/32	226	113	66.0
1/16	177	88.4	51.6
3/64	130	64.8	37.8
1/32	107	53.5	31.2
3/16	92.8	46.4	27.1
1/8	75.7	37.8	22.1
3/32	205	102	59.8
1/16	160	85.1	46.8
3/64	118	58.8	34.3
1/32	97.0	48.5	23.3
3/16	84.2	42.1	24.6
1/8	68.6	34.3	20.0
3/32	181	90.6	52.9
1/16	142	70.8	41.3
3/64	104	51.9	30.3
1/32	85.8	42.9	25.0

Standard 3/8 inch Tool			
3/32	220	110	64.2
1/16	169	84.6	40.4
3/64	122	61.2	35.7
1/32	99.8	49.9	29.1
3/16	86.4	43.2	25.2
1/8	70.1	35.1	20.5
3/32	202	101	58.9
1/16	156	77.8	45.4
3/64	112	56.2	32.8
1/32	91.8	45.9	26.8
3/16	79.3	39.7	23.2
1/8	64.3	32.2	18.8

Standard $\frac{3}{8}$ inch Tool (Continued)		Cutting Speed in feet per minute on a tool which is to last 1 hour and 30 minutes before regrinding			
Depth of Cut in Inches	Feed in Inches	Cast Iron			
		Soft Cast Iron	Medium Cast Iron	Hard Cast Iron	
$\frac{3}{16}$	$\frac{64}{32}$	178	89.0	52.0	
	$\frac{32}{16}$	137	68.6	40.1	
	$\frac{16}{8}$	99.4	49.7	29.0	
	$\frac{8}{4}$	81.0	40.5	23.7	
	$\frac{4}{2}$	70.1	35.0	20.5	
	$\frac{2}{1}$	56.8	28.4	16.6	
	$\frac{64}{32}$	163	81.5	47.7	
	$\frac{32}{16}$	126	62.9	36.7	
	$\frac{16}{8}$	90.8	45.4	26.5	
	$\frac{8}{4}$	74.1	37.0	21.6	
	$\frac{4}{2}$	64.1	32.0	18.7	
	$\frac{1}{4}$	$\frac{64}{32}$	52.0	26.0	15.2
$\frac{32}{16}$		44.4	21.8	12.9	
$\frac{16}{8}$		37.7	18.8	11.4	
$\frac{8}{4}$		32.3	16.3	9.9	
$\frac{64}{32}$		80.0	40.0	23.4	
$\frac{32}{16}$		65.3	32.6	19.1	
$\frac{16}{8}$		56.4	28.2	16.5	
$\frac{8}{4}$		45.8	22.9	13.4	
$\frac{64}{32}$		135	67.5	39.4	
$\frac{32}{16}$		104	52.1	30.4	
$\frac{16}{8}$		75.2	37.6	22.0	
$\frac{1}{2}$		$\frac{64}{32}$	61.4	30.7	17.9
	$\frac{32}{16}$	43.1	21.6	12.6	
	Standard $\frac{1}{2}$ inch Tool				
	$\frac{64}{32}$	222	111	65.0	
	$\frac{32}{16}$	169	84.3	49.2	
	Standard $\frac{5}{8}$ inch Tool				
	$\frac{64}{32}$	120	59.8	34.9	
	$\frac{32}{16}$	87.0	48.5	28.3	
	$\frac{16}{8}$	83.4	41.7	24.4	
	$\frac{8}{4}$	66.4	33.2	19.4	
	$\frac{64}{32}$	203	102	59.3	
	$\frac{32}{16}$	150	78.2	45.6	
$\frac{16}{8}$	110	55.0	32.0		
$\frac{8}{4}$	88.8	44.4	25.9		
$\frac{64}{32}$	76.2	38.1	22.3		
$\frac{32}{16}$	60.9	30.4	17.8		
$\frac{16}{8}$	48.1	24.9	15.2		
$\frac{8}{4}$	40.0	20.5	12.9		
$\frac{64}{32}$	97.7	48.9	28.5		
$\frac{32}{16}$	78.0	39.0	22.8		
$\frac{16}{8}$	67.5	33.7	19.7		
$\frac{8}{4}$	54.2	27.1	15.8		
Standard $\frac{3}{4}$ inch Tool					
$\frac{64}{32}$	167	83.6	48.8		
$\frac{32}{16}$	126	63.2	36.9		
$\frac{16}{8}$	90.8	45.4	26.3		
$\frac{8}{4}$	72.7	36.3	21.2		
$\frac{64}{32}$	62.7	31.3	18.3		
$\frac{32}{16}$	45.0	22.5	13.9		
$\frac{16}{8}$	37.7	18.8	11.4		
$\frac{8}{4}$	32.3	16.3	9.9		
Standard $\frac{7}{8}$ inch Tool					
$\frac{64}{32}$	113	56.7	33.1		
$\frac{32}{16}$	81.0	40.5	23.6		
$\frac{16}{8}$	65.5	32.7	19.1		
Standard 1 inch Tool					
$\frac{64}{32}$	216	108	63.0		
$\frac{32}{16}$	160	80.0	46.6		
$\frac{16}{8}$	110	55.0	32.2		
$\frac{8}{4}$	88.4	44.2	25.8		
$\frac{64}{32}$	75.4	37.7	22.0		
$\frac{32}{16}$	200	100	58.6		
$\frac{16}{8}$	148	74.0	43.3		

$\frac{1}{8}$	$\frac{1}{16}$	104	51.8	30.2
$\frac{3}{16}$	$\frac{3}{32}$	82.6	41.3	24.1
$\frac{1}{4}$	$\frac{1}{8}$	69.6	34.8	20.3
$\frac{5}{16}$	$\frac{3}{16}$	183	91.6	68.0
$\frac{3}{8}$	$\frac{1}{4}$	135	67.5	39.4
$\frac{7}{16}$	$\frac{3}{8}$	94.0	47.0	27.4
$\frac{1}{2}$	$\frac{1}{2}$	75.4	37.7	22.0
$\frac{5}{8}$	$\frac{3}{4}$	64.3	32.2	18.8
$\frac{3}{4}$	$\frac{7}{8}$	171	85.7	50.1
$\frac{7}{8}$	$\frac{1}{1}$	126	63.2	36.9
$\frac{1}{1}$	$\frac{1}{1}$	87.8	43.9	25.6
$\frac{1}{1}$	$\frac{1}{1}$	70.4	35.2	20.6
$\frac{1}{1}$	$\frac{1}{1}$	156	77.8	45.4
$\frac{1}{1}$	$\frac{1}{1}$	116	57.8	33.9
$\frac{1}{1}$	$\frac{1}{1}$	79.7	39.9	23.3

$\frac{3}{32}$	$\frac{1}{64}$	206	103	60.0
$\frac{1}{8}$	$\frac{1}{32}$	147	73.3	42.8
$\frac{3}{16}$	$\frac{1}{16}$	97.5	48.8	28.5
$\frac{1}{4}$	$\frac{3}{32}$	76.0	38.0	22.2
$\frac{5}{16}$	$\frac{1}{8}$	64.1	32.1	18.7
$\frac{3}{8}$	$\frac{1}{4}$	194	97.0	56.7
$\frac{1}{2}$	$\frac{3}{8}$	138	69.3	40.4
$\frac{3}{4}$	$\frac{1}{2}$	93.1	46.5	27.2
$\frac{7}{8}$	$\frac{3}{4}$	72.1	36.1	21.3
$\frac{1}{1}$	$\frac{7}{8}$	41.8	20.9	12.2
$\frac{3}{16}$	$\frac{1}{8}$	182	91.0	53.0
$\frac{1}{4}$	$\frac{1}{4}$	128	64.0	37.7
$\frac{3}{8}$	$\frac{1}{8}$	86.1	43.1	25.1
$\frac{1}{2}$	$\frac{1}{4}$	67.4	33.7	19.6
$\frac{3}{4}$	$\frac{1}{2}$	173	86.3	50.4
$\frac{7}{8}$	$\frac{3}{4}$	122	61.0	35.7
$\frac{1}{1}$	$\frac{1}{1}$	81.9	41.0	23.9

CHAPTER VI

STRAIGHT AND CIRCULAR FORMING TOOLS

Almost every machinist who is engaged in tool work will have more or less to do with the making of forming tools. These may be used for shaping sheet metals, or for use under the drop hammer, or again, they may be employed in the lathe, planer, shaper, or milling machine. It is the object in the present chapter, however, to confine ourselves to a description of the straight and circular forming tools that are so universally used on screw machines. For certain purposes these tools need not be of a very exact nature, while, again, they require great accuracy in their construction when they are to be used for the manufacture of interchangeable parts. As the old saying goes: "It is easy enough to make one alike," but when it is necessary to make duplicate tools it is quite a difficult task.

While there are numerous methods employed for making these tools,

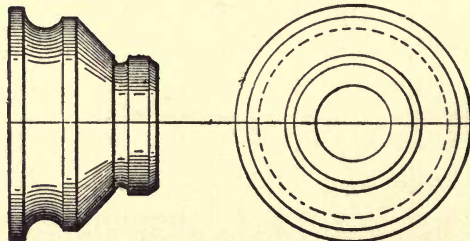

Fig. 51. Piece of Work to be Made

but little has ever been written in a way which will enable the machinist to compute the distances, diameters, or angles so as to produce the required dimensions on the finished work. If, for instance, a circular tool is to produce certain diameters on the work, and we transfer the exact ratio of these different diameters from the drawing to the forming tool, we will not be able to get the required dimensions when the cutting edge of the tool is one-quarter of an inch below the center. If we have to make a straight forming tool which, in the machine, is to stand at an angle of 15 degrees, we can, when it is not very wide, avail ourselves of the use of a master forming tool. When, however, the tool is very wide, so that the use of the master tool is unpractical, and it is necessary to mill or plane it to shape, some computation is then necessary in order to make the shape such that it will produce the required dimensions on the work when the tool is held at an angle in the machine.

Making Straight Forming Tools*

We will first consider a method of making straight forming tools which has proved satisfactory and will produce accurate results if

* MACHINERY, June, 1904.

properly manipulated. We will suppose that we are called upon to make the tools for producing with accuracy such a piece of work as shown in Fig. 51, and that a master former is to be made so that at any future time the forming tool can be duplicated at small expense. The master former will be made as in Fig. 52, being an accurate duplicate of our model with the addition of a shank about an inch and a half in length on each end, these shanks serving as an arbor for the tool.

The formed part is then milled down to the center, to produce a cutting face for future operations, after which it is hardened, tempered and the face accurately ground. To facilitate this face grinding the fixture shown in Fig. 53 is employed, the work being done on a surface grinder. The most essential point to be observed in grinding such a former is to have the cutting face radial, and this is accomplished by the use of this fixture. The fixture is placed on the grinder so that the line of centers is at right angles with the emery wheel; the center *c* is removed from the block *d*, and the emery wheel is

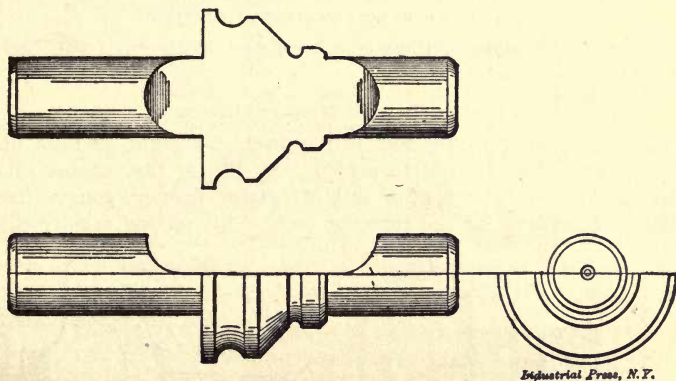

Fig. 52. Master Former

Industrial Press, N. Y.

brought to bear on the ball *b*, which is a running fit in the lever *a*. This lever is fulcrumed on the block *d* and is held upward by means of a spring attached to the short arm. With the emery wheel at rest, the table of the grinder is now run back and forth and the wheel fed downward until it reaches such a position that when it passes over the ball *b*, the front end of the lever will indicate zero. This shows the operator that the periphery of the wheel is in perfect alignment with the center of the fixture. The center *c* is then replaced and the master former, with dog attached, is placed between the centers and ground. By the use of the handle *e*, which engages the knurled head of the adjustable center, the former is turned slightly after each cut across the face until a keen cutting edge on the same is obtained.

The block from which the forming tool is to be made is placed in the vise of the milling machine and roughed out as near to the formed shape as possible, after which the master former is substituted for the milling cutter, as shown in Fig. 54. The cutting face must stand

at the same angle with the perpendicular as the forming tool is to stand when placed in the screw machine, and it is very essential to observe this point if accurate results are desired. When the proper angle of the former has been obtained, it is secured in position by a wooden wedge tapped in between the cone and the frame of the milling

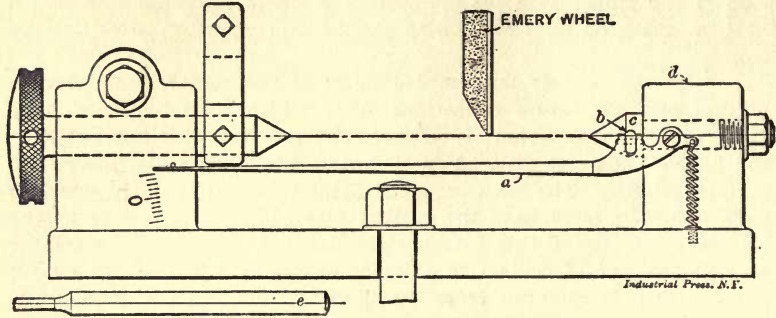

Fig. 53. Device for Grinding Master Former

machine, and the table is then run back and forth until the forming tool is cut to the desired shape.

Use of Second Master Former

If an extra long forming tool is required, say eight or nine inches in length, and it is desired to prolong the life of the master former, we would then make use of a second master former, constructed as previously described for the forming tool. This second master former

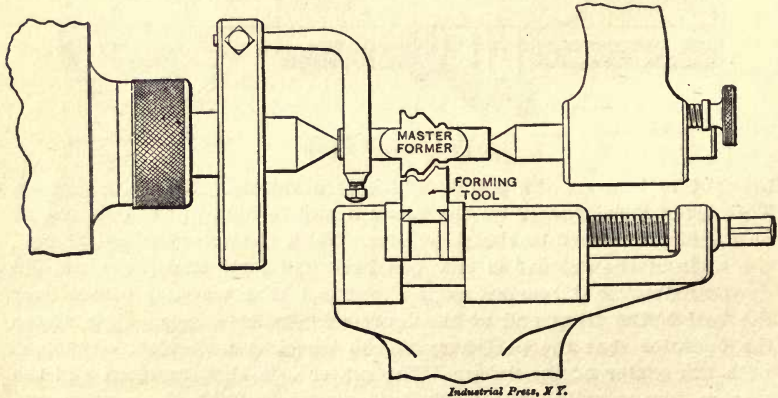

Fig. 54. Making the Forming Tool from the Master Former

fits into a holder, as shown in Fig. 55, and when it is being formed should be held at right angles with the bed of the machine. It is then necessary to make a similar piece to be used for making the working formers. To avoid confusion we will call this first piece No. 1 and the next piece to be made No. 2. This second piece must have the form of No. 1 transferred to it and for this purpose it is

placed in the block shown in Fig. 56, which holds it at an angle of 10 degrees with the shaper vise. Piece No. 1, in its holder, is placed in the toolpost of the shaper where a tapered block holds it at a corresponding angle with piece No. 2, so that their faces are in line, as shown in Fig. 57. By locating these pieces in this way the form of No. 1 can be accurately transferred to No. 2, at the same time giving No. 2 the required clearance so that it can then be held squarely in the shaper toolpost and used to shape the forming tools that are held in the shaper vise at an angle of 10 degrees.

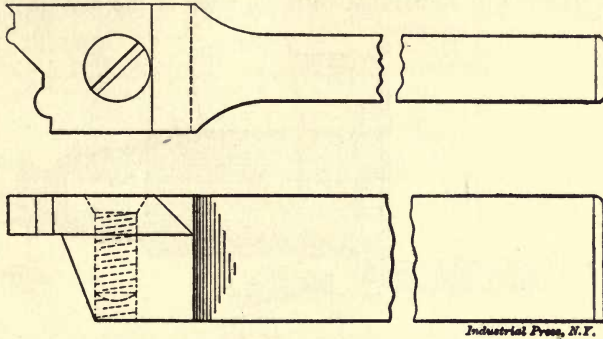

Fig. 55. Second Master Former and Holder

To make this last method clear we must bear in mind that at whatever angle the forming tool stands when in the screw machine, this angle must be maintained for setting the face of the master former. This transfers the form to No. 1 and overcomes the discrepancy caused by the tool standing at an angle in the screw machine, and this when in turn transferred to No. 2 gives it the clearance required and the exact shape of No. 1.

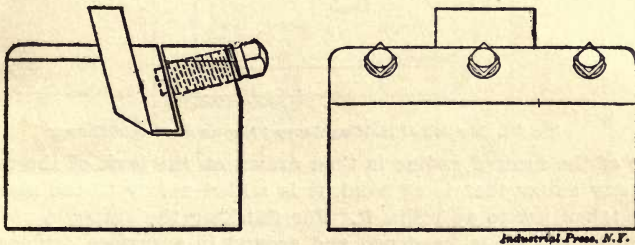

Fig. 56. Method of Holding Forming Tool while Shaping

There are numerous other methods in use for accomplishing this class of work and some, no doubt, may be simpler, but they do not yield such accurate results. One of these methods consists in filing a templet to fit the model and from this making the shaping tool, which in turn is placed in the shaper with the face standing at the same angle as will the forming tool when placed in the screw machine. Then the forming tool blank is put in the vise and shaped up in the usual way.

Making Concave Forming Tools in the Milling Machine*

Fig. 58 illustrates a very interesting method of making a concave forming tool such as is used for backing off convex milling cutters. This tool has, of course, the same shape for its entire depth so that it may be ground and reground without changing its original form.

In Fig. 58, *B* represents the tool which is held in the holder *A* at an angle of 76 degrees with the table of the milling machine, this giving to the tool the proper cutting clearance. The first thing to be done, after placing the tool in the holder, is to mill off the top of the tool so that it will be parallel with the table of the machine. A semi-

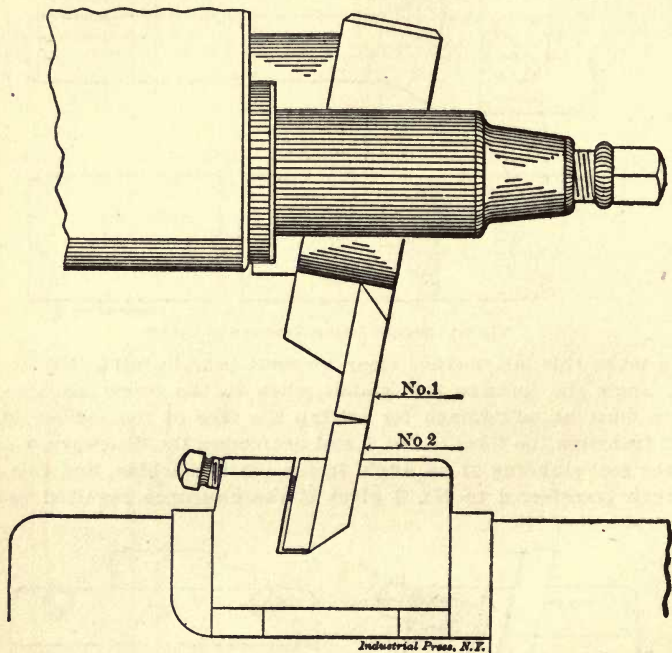

Fig. 57. Method of Holding Second Master Former in Shaper

circle of the desired radius is then drawn on the back of the tool, and with any cutter that is at hand, it is milled nearly to the mark, care being taken not to go below it. For finishing the cutter, a plug, *C*, is made, the end being hardened and ground in a surface grinder. This plug is held in a special holder, *D*, which fits the spindle of the milling machine, and when it is set so that its axis is perpendicular to the tool, the spindle of the machine is firmly locked. Some machines are now being built with provision for locking the spindle, but if not so made the same result may be accomplished by driving wedges under the cone pulley. Now, by moving the platen of the machine backward and forward by hand, the plug can be made to cut a perfect semi-circle in the tool.

* MACHINERY, December, 1903.

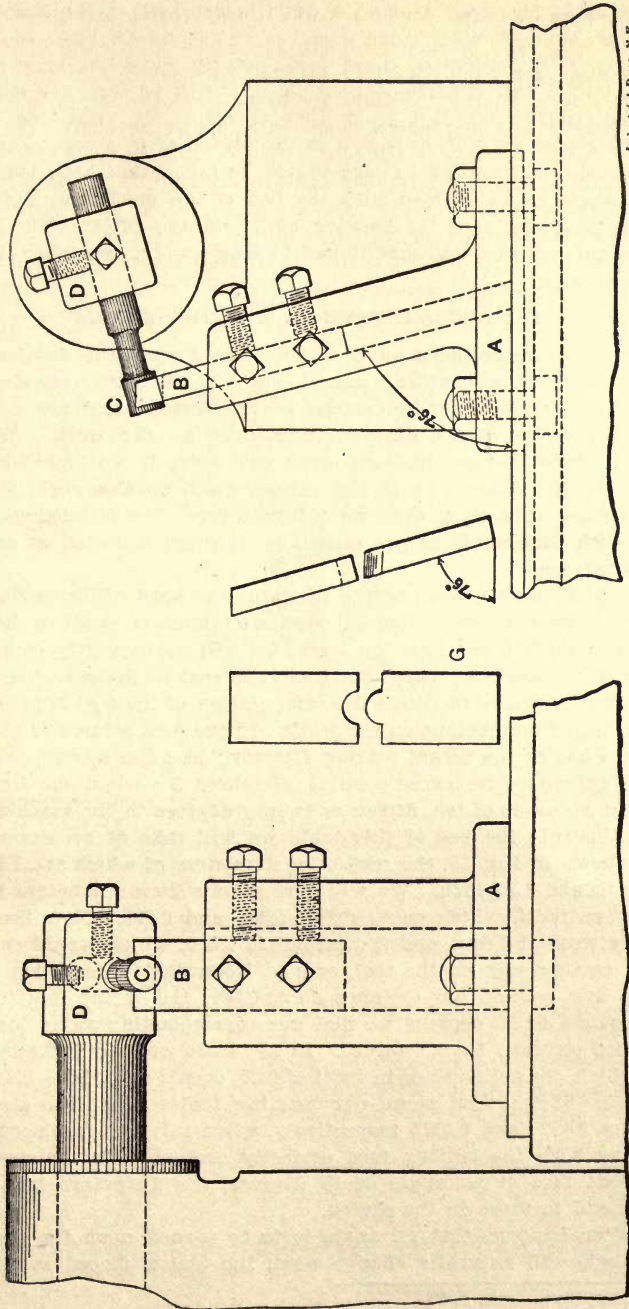

Fig. 58. Making a Concave Forming Tool in the Milling Machine

Industrial Press, N. Y.

It is good practice to plane a little below half of the diameter of the plug, thus allowing some stock to be ground off after the tool is hardened. In hardening, these tools usually come out very satisfactorily, but, if any distortion takes place, it will be from the sides, and may be readily remedied by a little stoning. By using the concave tool for a planing tool, as shown in the sketch at *G*, a convex tool may be formed, but in doing so care should be taken that both tools stand at an angle of 76 degrees with the bed of the machine. This shape of tool would be used for backing off a concave cutter. The description of this method was contributed to *MACHINERY*, December, 1903, by J. J. Lynskey.

Computing Dimensions for Forming Tools*

The foregoing methods have all been based upon the duplication of the formers by mechanical means, but we will now consider other methods in which the dimensions of the formed tool are computed from the ratios of the different diameters on the work. We have already made it clear that an error will exist if we transfer to the tool the exact differences in the various radii on the work, and it is to overcome this error that we subtract from the dimensions of the work such differences as are caused by the tool standing at an angle in the machine.

As will be readily seen in the figure at the head of Table No. 1, the line *ac* is always longer than *bc*, and as *ac* must be equal to the difference between two radii on the work, *bc* will consequently equal $ac \times$ cosine of the angle at which the tool is to rest in the machine. Table No. 1 is arranged to facilitate the computation of the tool dimensions to give required dimensions on the work. In the first column is given the distance *ac*, or the actual cutting distance; and the second, third and fourth columns give corresponding distances *bc* when the tool is to stand at an angle of ten, fifteen or twenty degrees in the machine.

To illustrate the use of this table we will take as an example the piece shown in Fig. 59, the respective diameters of which are 1.75 inch, 0.75 inch and 1.25 inch. We will first reduce these diameters to their respective radii, which equal 0.875, 0.375 and 0.625. Now the difference between the first and the second is 0.500, which would equal the actual cutting edge on the tool, or *ac*. Referring to our table we find in the first column our distance $ac = 0.500$, and if the tool is to set at an angle of 15 degrees we find our corresponding value for *bc* in the third column; $bc = 0.482965$. In the same way we find our second step which, for a difference in radii of 0.25, equals $0.193186 + 0.048297 = 0.241483$. If we then plane our forming tool so that the steps will measure 0.4830 and 0.2415 respectively, when this tool is placed in the machine with the cutting face perfectly central with the work, and the front face at an angle of 15 degrees, the diameters turned will correspond to those in the sketch.

It often happens that an angle is to be turned upon the piece and this angle will naturally change when the tool is placed at an angle.

* *MACHINERY*, June, 1904.

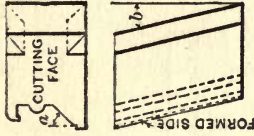

TABLE NO. 2. COMPUTED ANGLES ON STRAIGHT FORMING TOOLS

$a =$ Angle on Cutting Face of Forming Tool.	Angle Measured on Formed Side, which coincides with Angle A on Cutting Face, when Forming Tool stands at 10, 15 or 20 degrees from Perpendicular.		
	$b = 10$ degrees.	$b = 15$ degrees.	$b = 20$ degrees.
5°	4° - 55'	4° - 50'	4° - 42'
10	9 - 51	9 - 40	9 - 24
15	14 - 47	14 - 31	14 - 08
20	19 - 43	19 - 22	18 - 53
25	24 - 40	24 - 15	23 - 40
30	29 - 37	29 - 09	28 - 29
35	34 - 35	34 - 04	33 - 20
40	39 - 34	39 - 01	38 - 15
45	44 - 34	44 - 00	43 - 13
50	49 - 34	49 - 01	48 - 14
55	54 - 35	54 - 04	53 - 18
60	59 - 37	59 - 08	58 - 26
65	64 - 40	64 - 14	63 - 36
70	69 - 43	69 - 21	68 - 50
75	74 - 47	74 - 30	74 - 5
80	79 - 51	79 - 39	79 - 22
85	84 - 55	84 - 49	84 - 41

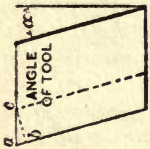

TABLE NO. 1. USED IN MAKING STRAIGHT FORMING TOOLS

Actual Cutting Distance.	b, c Angle of Tool 10°	b, c Angle of Tool 15°	b, c Angle of Tool 20°
.001	.000985	.000965	.000940
.002	.001970	.001952	.001879
.003	.002954	.002898	.002819
.004	.003939	.003864	.003759
.005	.004924	.004830	.004699
.006	.005909	.005796	.005638
.007	.006894	.006762	.006578
.008	.007878	.007727	.007518
.009	.008863	.008693	.008457
.010	.009848	.009639	.009397
.020	.019696	.019319	.018794
.030	.029544	.028978	.028191
.040	.039392	.038637	.037588
.050	.049241	.048297	.046985
.060	.059089	.057956	.056381
.070	.068937	.067615	.065778
.080	.078785	.077274	.075175
.090	.088633	.086934	.084572
.100	.098481	.096593	.093969
.200	.196962	.193186	.187988
.300	.295443	.289779	.281907
.400	.393924	.386372	.375876
.500	.492405	.482965	.469845

Table No. 2 has therefore been computed to give the angle that is to be made on the tool for obtaining a required angle on the work. The angles given are measured from the center line of the piece or, what is the same thing, with the formed face of the tool. Thus in Fig. 59 we have an angle of 45 degrees, and as the forming tool will rest at an angle of 15 degrees in the machine, we refer to the third column of Table No. 2, where we find 44 degrees as the proper angle for the tool, and if the tool is made to this angle it will cut the work to the 45 degrees required. The angular difference, as will be seen, is the

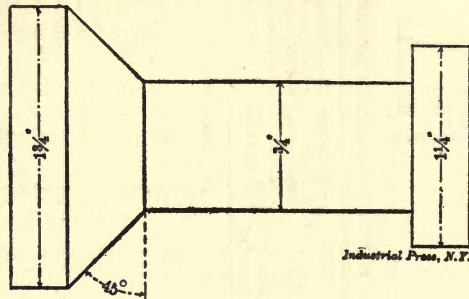

Fig. 59. Example of Work for which Forming Tool Dimensions are to be Computed greatest at 45 degrees, from which it decreases at about the same rate toward zero and 90 degrees.

Circular Forming Tools

Circular forming tools are used in the same capacity as straight ones, and to make them accurately entails quite a little computation. Whenever a circular tool has two or more diameters a discrepancy will exist between the different diameters on the tool and on the

$$\begin{aligned}
 OC &= \text{Radius of forming tool.} \\
 OB &= \text{Second radius of forming tool.} \\
 OA &= \text{Distance from center to cutting face of tool.} \\
 AB &= \sqrt{OB^2 - OA^2} \\
 BC &= \sqrt{OC^2 - OA^2} - \sqrt{OB^2 - OA^2}
 \end{aligned}$$

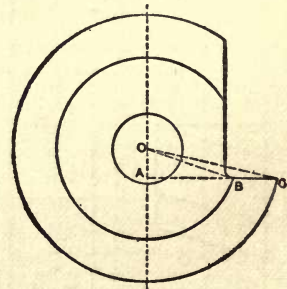

Fig. 60. Formulas for Circular Forming Tools

work, if the cutting face is below the center of the tool. In Fig. 60 are given the formulas necessary for calculating the diameters of circular forming tools, and Table No. 3 has been computed to show the discrepancies and to assist in determining the proper diameters of formed tools to give required diameters on the work. The first and second columns give the diameters and radii respectively of the formed tools, while the third column gives the distance from the vertical

TABLE NO. 8. FOR COMPUTING DIAMETERS OF CIRCULAR FORMING TOOLS

Diameter of Tool = ϕ C	CUTTING FACE $\frac{1}{2}\phi$ BELOW CENTER.				CUTTING FACE $\frac{3}{4}\phi$ BELOW CENTER.				CUTTING FACE ϕ BELOW CENTER.				CUTTING FACE $\frac{1}{2}\phi$ BELOW CENTER.			
	A	C	Correction for $\frac{1}{4}\phi$ Difference In Diameter.	Correction for $\frac{1}{2}\phi$ Difference In Diameter.	A	C	Correction for $\frac{1}{4}\phi$ Difference In Diameter.	Correction for $\frac{1}{2}\phi$ Difference In Diameter.	A	C	Correction for $\frac{1}{4}\phi$ Difference In Diameter.	Correction for $\frac{1}{2}\phi$ Difference In Diameter.	A	C	Correction for $\frac{1}{4}\phi$ Difference In Diameter.	Correction for $\frac{1}{2}\phi$ Difference In Diameter.
1	500	48412	00003	00000	46351	00864	00000	00000	43301	01676	00000	00000	39081	02960	00000	00000
1 1/4	5625	54843	00238	00050	53083	00876	01540	00000	50889	01286	02963	00000	46771	02960	00000	00000
1 1/2	625	61237	00238	00050	59621	00876	01540	00000	57282	01286	02963	00000	54136	02210	05190	00000
1 3/4	6875	67604	00234	00048	66148	00544	00094	00000	64044	01024	00000	00000	61237	01732	00000	00000
1 3/8	750	73951	00194	00028	72618	00450	00094	02354	70710	00832	01856	04818	68179	01854	08108	08296
1 1/8	8125	80282	00193	00028	79066	00376	00098	00000	77308	00696	00000	00000	75000	01142	00000	00000
1 1/4	875	86602	00140	00020	85467	00322	00098	00000	83852	00388	01284	00000	81729	00956	02100	00000
1 3/8	9375	92112	00120	00026	91855	00276	00018	01216	90355	00506	00000	00000	88388	00818	00000	00000
1 3/4	1000	99315	00106	00026	98226	00242	00018	00000	96825	00440	00946	02280	94991	00708	01524	03624
1 1/2	10625	105512	00094	00026	104882	00212	00018	00000	103267	00384	00000	00000	101550	00618	00000	00000
1 1/4	1125	111803	00083	00176	110926	00188	00400	00000	109987	00340	00724	00000	108072	00544	01162	00000
1 1/8	11875	118090	00074	00140	117260	00168	00018	00000	116086	00284	00000	00000	114564	00454	00000	00000
1 3/8	1250	124370	00066	00140	123580	00150	00318	00718	122475	00278	00572	01296	121082	00436	00920	02082
1 1/2	13125	130653	00060	00114	129904	00138	00260	00000	128847	00244	00466	00000	127475	00386	00000	00000
1 3/4	1375	136880	00054	00114	136215	00122	00260	00000	135208	00222	00466	00000	133901	00382	00788	00000
1 1/4	14375	143205	00050	00096	142521	00112	00000	00000	141559	00202	00000	00000	140312	00822	00000	00000
1 3/8	1500	149478	00046	00096	148823	00104	00216	00476	147902	00186	00858	00854	146708	00282	00614	01332
1 1/2	15625	155749	00042	00080	155120	00094	00000	00000	154287	00170	00000	00000	153093	00270	00000	00000
1 3/4	1625	162018	00038	00080	161414	00082	00182	00000	160565	00156	00826	00000	159466	00246	00516	00000
1 1/8	16875	168286	00036	00070	167705	00082	00000	00000	166883	00144	00000	00000	165881	00280	00000	00000
1 3/8	1750	174553	00034	00070	173992	00074	00156	00338	173205	00136	00280	00606	172187	00212	00442	00908
1 1/2	18125	180818	00032	00060	180277	00070	00136	00000	179518	00126	00000	00000	178535	00196	00882	00000
1 3/4	1875	187560	00028	00060	186560	00066	00136	00000	185826	00116	00242	00000	184877	00186	00882	00000
1 1/8	19375	193346	00026	00050	192540	00060	00000	00000	191830	00108	00000	00000	191218	00172	00000	00000
1 3/8	2000	199608	00024	00050	199119	00058	00118	00254	198431	00102	00210	00452	197548	00160	00882	00714

center line of the tool to the cutting edge when the cutting face is $\frac{1}{4}$ inch below the horizontal center line. The following three columns give the constants that are to be used in computing the various diameters of the forming tools when the cutting face is $\frac{1}{8}$ inch below the horizontal center line, as will be made clear in the example following. In the remaining columns are tabulated similar values as these, for use when the cutting face of the tool is $\frac{3}{16}$, $\frac{1}{4}$, and $\frac{5}{16}$ inch below the horizontal center line of the tool. As there is no standard distance for the location of the cutting face, the table has accordingly been prepared to correspond with such distances as are most commonly used.

As an example illustrating the use of these tables we will consider that we are to make a circular forming tool for the piece shown in Fig. 59, and that the largest diameter of the tool is to be 3 inches, and its cutting face $\frac{1}{4}$ inch below the horizontal center line. The first step will be to determine approximately the respective diameters of the forming tool and then to correct them by the use of the tables.

The diameters of the piece are 1.750, 0.750 and 1.250 respectively,

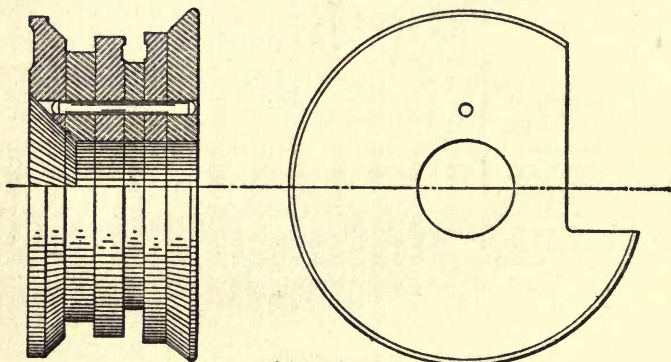

Industrial Press, N. Y.

Fig. 61. Forming Tool Built up of Sections

and to produce these with a 3-inch cutter the diameters of the tool would be approximately 2.000, 3.000, and 2.500 inches respectively. The first dimension, 2.000, is 1.000 inch in diameter less than that of the tool, and for the correction we would look in the column of differences for inches, but as the tables are only extended to half inches we will be obliged to obtain our correction in two steps. On the line for 3-inch diameter, and under corrections for $\frac{1}{2}$ inch, we find 0.00854; and then on line of $2\frac{1}{2}$ and under the same heading, we find 0.01296, consequently our total correction would be $0.00854 + 0.01296 = 0.02150$. This correction is added to the approximate diameter, making the exact diameter of our first step $2.000 + 0.02150 = 2.02150$ inches. Our next step would be computed in the same way by noting on the 3-inch line the correction for $\frac{1}{2}$ inch and adding it to the approximated diameter of our second step, giving us an exact diameter of $2.500 + 0.00854 = 2.50854$. Thus our tool, to produce the

piece shown in the example, would have three steps of 3.000, 2.0215, and 2.5085 inches, respectively, if it is to have its cutting face $\frac{1}{4}$ inch below center. All diameters are computed in this way, from the largest or fixed diameter of the tool.

In conclusion, attention should be called to the formed tool, illustrated in Fig. 61, which is made in sections so that all diameters, sides, and angles can be easily ground after the tool is hardened. This

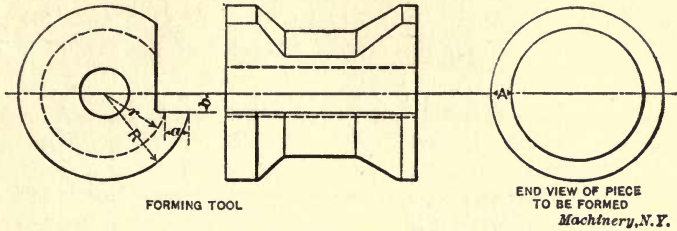

Fig. 62. Forming Tool and End View of Work

design is of especial value when such tools are made from high-speed steel, as the finished surfaces are likely to be roughened by the high heat that is necessary for hardening.

Formulas for Circular Forming Tools*

The formulas required for circular forming tools may, perhaps, be expressed somewhat simpler than has been previously done in this chapter. Assume in Fig. 62, for instance, that the distance A in the piece to be formed equals the distance a on the forming tool, but as

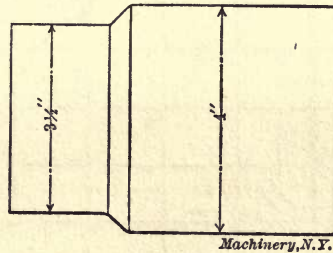

Fig. 63. Piece to be Formed

this latter distance is measured in a plane a certain distance b below the horizontal plane through the center of the forming tool, it is evident that the differences of diameter in the tool and the piece to be formed are not the same. A general formula may, however, be deduced by use of elementary geometry by means of which the various diameters of the forming tool may be determined if the largest (or smallest) diameter of the tool, the amount that the cutting edge is below the center, and, of course, the diameters of the piece to be formed, are known.

If R = largest radius of the tool,

a = difference in radii of steps in the work, and

* MACHINERY, January, 1908.

b = amount cutting edge is below center,
 then, if r be the radius looked for,

$$r = \sqrt{(\sqrt{R^2 - b^2} - a)^2 + b^2}$$

If the smaller radius r is given and the larger radius R sought, the formula takes the form:

$$R = \sqrt{(\sqrt{r^2 - b^2} + a)^2 + b^2}$$

Suppose, for an example, that a tool is to be made to form the piece in Fig. 63. Assume that the largest diameter of the tool is to be 3

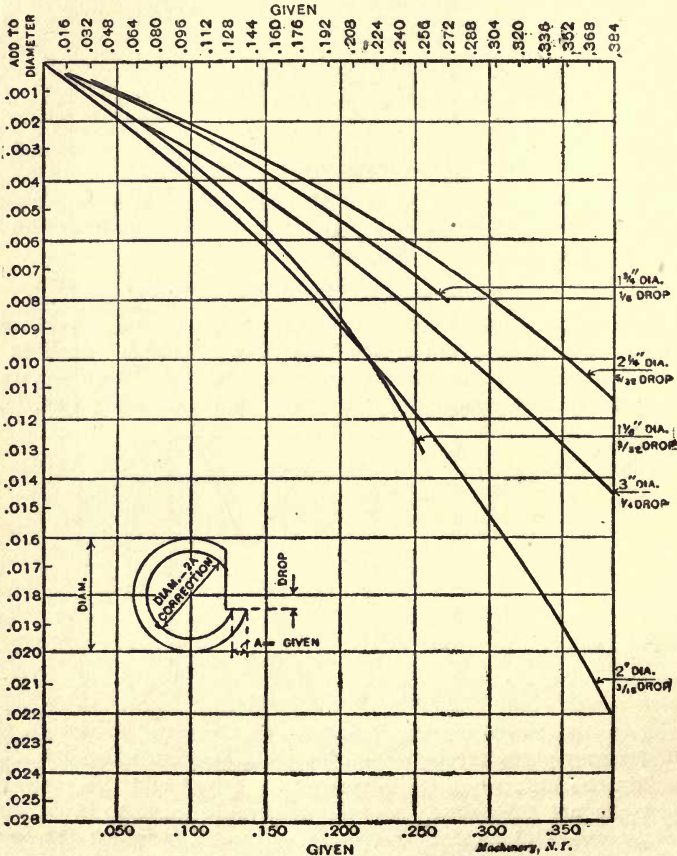

Fig. 64. Diagram for Circular Forming Tools

inches, and that the cutting edge is to be $\frac{1}{4}$ inch below the center of the tool. Then the diameter next smaller to 3 inches is found from the formulas given by inserting the given values: $R = 1\frac{1}{2}$ inch, $b = \frac{1}{4}$ inch, and $a = \frac{1}{4}$ inch (half the difference between 4 and $3\frac{1}{2}$ inches; see Fig. 63).

Then

$$r = \sqrt{(\sqrt{(\frac{1}{4})^2 - (\frac{1}{4})^2} - \frac{1}{4})^2 + (\frac{1}{4})^2} = \sqrt{(\sqrt{\frac{3}{16} - \frac{1}{16}} - \frac{1}{4})^2 + \frac{1}{16}} = \frac{5.017}{4} = 1.254 \text{ inch.}$$

While the formula looks complicated, by means of a table of squares the calculations are easily simplified and can be carried out in three or four minutes. The value of r being 1.254 inch, the diameter to make the smaller step of the forming tool will be 2.508 inches, instead of $2\frac{1}{2}$

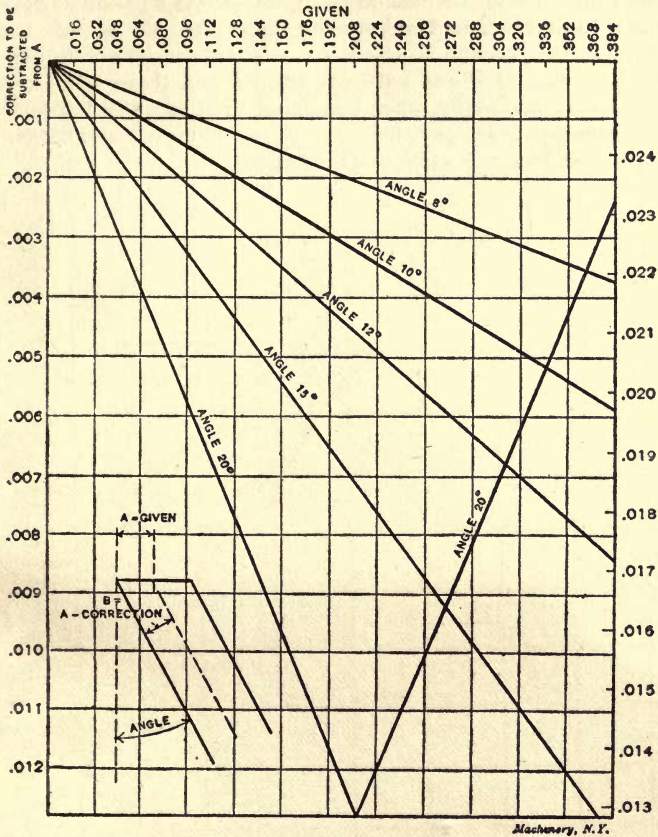

Fig. 65. Diagram for Straight Forming Tools

inches exact, as would have been the case if the cutting edge had been on the center line.

Charts for Dimensions of Forming Tools*

The charts in Figs. 64 and 65 have been computed for the same purpose as the tables just explained, and the various curves and lines thereon are made to correspond to what is generally used. An illus-

* MACHINERY, October, 1904.

tration of their use will offer the best way of explaining them. Referring to Chart Fig. 64, the distance A (see cut) thereon is calculated from whatever the piece is we have to make. Under the word "Given," at the top and bottom of the chart, locate A , and follow down (or up) the vertical line until it intersects the proper curve. This point, carried to the right by the horizontal line, will indicate the correction to be added to the diameter, after subtracting $2A$, of course. The horizontal divisions for the verticals vary by 0.016 inch and the corrections read to 0.001 inch which for practical use is as near as required. The same illustration will answer for Chart Fig. 65; in this the correction is carried around to the right of chart for larger values.

The Chart Fig. 64 shows only five curves, and there is no question but what there are many other standards so it is quite impossible to make a complete chart or table. Unless we know all standards, however, it is best to avoid useless calculations.

UNIVERSITY OF CALIFORNIA LIBRARY
BERKELEY

Return to desk from which borrowed.
This book is DUE on the last date stamped below.

DEC 3 1947

DEC 1 1970

JAN 19 1948 REC'D LD NOV 30 70 -10 AM 3 3

JAN 24 1948

5 May '49 HJ

NOV 13 1971 45

27 Oct '52 GR
OCT 13 1952 LU

LIBRARY USE ONLY

MAR 22 1993

CIRCULATION DEPT.

25 Oct '57 RB

REC'D LD

AUTO DISC CIRC MAR 22 '93

OCT 16 1957

REC'D LD

NOV 1 71 -9 PM 9 3



C042167070

JJ7
M3
v.7

347518

machinery's

UNIVERSITY OF CALIFORNIA LIBRARY

CONTENTS OF DATA SHEET BOOKS

No. 1. Screw Threads.—United States, Whitworth, Sharp V- and British Association Standard Threads; Briggs' Pipe Thread; Oil Well Casing Gages; Fire Hose Connections; Acme Thread; Worm Threads; Metric Threads; Machine, Wood, and Lag Screw Threads; Carriage Bolt Threads, etc.

No. 2. Screws, Bolts and Nuts.—Filter-head, Square-head, Hexless, Collar-head and Hexagon-head Screws; Standard and Special Nuts; T-nuts, T-bolts and Washers; Thumb Screws and Nuts; A. L. A. M. Standard Screws and Nuts; Machine Screw Heads; Wood Screws; Tap Drills; Lock Nuts; Eye-bolts, etc.

No. 3. Taps and Dies.—Hand, Machine, Tapper and Machine Screw Taps; Taper Die Taps; Sellers' Machine Screw Machine Taps; Straight and Taper Boiler Taps; Stay-bolt, Was out, and Patch-bolt Taps; Pipe Taps and Hobs; Solid Square, Round Adjustable and Spring Screw Threading Dies.

No. 4. Reamers, Sockets, Drills and Milling Cutters.—Hand and Reamers; Shell Reamers and Arbors; Pipe Reamers; Taper Pins and Reamers; Brown and Sharpe, Morse and Jarno Taper Sockets and Reamers; Drills; Wire Gages; Milling Cutters; Setting Angles for Milling Teeth in End Mills and Angular Cutters, etc.

No. 5. Spur Gearing.—Diametral and Circular Pitch; Dimensions of Spur Gears; Tables of Pitch Diameters; Odontograph Tables; Rolling Mill Gearing; Strength of Spur Gears; Horsepower Transmitted by Cast-iron and Railway Pinions; Design of Spur Gears; Weight of Cast-iron Gears; Epicyclic Gearing.

No. 6. Bevel, Spiral and Worm Gearing.—Rules and Formulas for Bevel Gears; Strength of Bevel Gears; Design of Bevel Gears; Rules and Formulas for Spiral Gearing; Tables Facilitating Calculations; Diagram for Cutters for Spiral Gears; Rules and Formulas for Worm Gearing, etc.

No. 7. Shafting, Belts and Keyways.—Horsepower of Shafting; Diagrams and Tables for the Strength of Shafting; Forcing, Drawing, Shrinking and Running Fits; Woodruff Keys; United States Navy Standard Keys; Gib Keys; Milling Keyways; Duplex Keys.

No. 8. Bearings, Couplings, Clutches, Crane Chain and Hooks.—Pillow Blocks; Babbitted Bearings; Ball and Roller Bearings; Clamp Couplings; Plate Couplings; Flange Couplings; Tooth Clutches; Crab Couplings; Cone Clutches; Universal Joints; Crane Chain; Chain Friction; Crane Hooks; Drum Scales.

No. 9. Springs, Slides and Machine Details.—Formulas and Tables for Spring Calculations; Machine Slides; Machine Handles and Levers; Collars; Hand Wheels; Pins and Cotter; Turn-buckles, etc.

No. 10. Motor Drive, Speeds and Feeds, Change Gearing, and Boring Bars.—Power required for Machine Tools; Cutting Speeds and Feeds for Carbon and High-speed Steel; Screw Machine Speeds and Feeds; Heat Treatment of High-speed

Steel Tools; Taper Turning; Change Gearing for the Lathe; Boring Bars and Tools, etc.

No. 11. Milling Machine Indexing, Clamping Devices and Planer Jacks.—Tables for Milling Machine Indexing; Change Gears for Milling Spirals; Angles for setting Indexing Head when Milling; Clutches; Jig Clamping Devices; Strap and Clamps; Planer Jacks.

No. 12. Pipe and Pipe Fittings.—Pipe Threads and Gages; Cast Iron Fittings; Bronze Fittings; Pipe Flanges; Pipe Bends; Pipe Clamps and Hangers; Dimensions of Pipe for Various Services, etc.

No. 13. Boilers and Chimneys.—Flue Spacing and Bracing for Boilers; Strength of Boiler Joints; Riveting; Boiler Setting; Chimneys.

No. 14. Locomotive and Railway Data.—Locomotive Boilers; Bearing Pressures for Locomotive Journals; Locomotive Classifications; Rail Sections; Frogs, Switches and Cross-overs; Tires; Tractive Force; Inertia of Trains; Brake Levers; Brake Rods, etc.

No. 15. Steam and Gas Engines.—Saturated Steam; Steam Engine Sizes; Steam Engine Design; Volume of Cylinders; Stuffing Boxes; Setting Corliss Engine Valve Gears; Condenser and Air Pump Data; Horsepower of Gasoline Engines; Automobile Engine Crankshafts, etc.

No. 16. Mathematical Tables.—Squares of Mixed Numbers; Functions of Fractions; Circumference and Diameters of Circles; Tables for Spacing off Circles; Solution of Triangles; Formulas for Solving Regular Polygons; Geometrical Progression, etc.

No. 17. Mechanics and Strength of Materials.—Work; Energy; Centrifugal Force; Center of Gravity; Motion Friction; Pendulum; Falling Bodies; Strength of Materials; Strength of Flat Plates; Ratio of Outside and Inside Radii of Thick Cylinders, etc.

No. 18. Beam Formulas and Structural Design.—Beam Formulas; Sectional Moduli of Structural Shapes; Beam Charts; Net Areas of Structural Angles; Rivet Spacing; Splices for Channels and I-beams; Stresses in Roof Trusses, etc.

No. 19. Belt, Rope and Chain Drives.—Dimensions of Pulleys; Weights of Pulleys; Horsepower of Belting; Belt Velocity; Angular Belt Drives; Horsepower transmitted by Ropes; Sheaves for Rope Drive; Bending Stresses in Wire Ropes; Sprockets for Link Chains; Formulas and Tables for Various Classes of Driving Chain.

No. 20. Wiring Diagrams, Heating and Ventilation, and Miscellaneous Tables.—Typical Motor Wiring Diagrams; Resistance of Round Copper Wire; Rubber Covered Cables; Current Densities for Various Contacts and Materials; Centrifugal Fan and Blower Capacities; Hot Water Main Capacities; Miscellaneous Tables; Decimal Equivalents; Metric Conversion Tables; Weights and Specific Gravity of Metals; Weights of Fillets; Drafting-room Conventions, etc.

MACHINERY, the monthly mechanical journal, originator of the Reference and Data Sheet Series, is published in three editions—the *Shop Edition*, \$1.00 a year; the *Engineering Edition*, \$2.00 a year, and the *Foreign Edition*, \$3.00 a year.

The Industrial Press, Publishers of MACHINERY,
49-55 Lafayette Street,

New York City, U. S. A.